

KIMRAY
INC.®

INSTALLATION
OPERATION &
MAINTENANCE
GUIDE



PRESSURE REGULATOR
BACK PRESSURE TO ATMOSPHERE WITH OUTSIDE SUPPLY

PRESSURE REGULATORS



*MODEL: Back Pressure to Atmosphere
Installation, Operation & Maintenance Guide*

All Rights Reserved.

All contents of this publication including illustrations are believed to be reliable. And while efforts have been made to ensure their accuracy, they are not to be construed as warranties for guarantees, express or implied, regarding Kimray products or services described herein or their use or application. All sales are governed by our terms and conditions, which are available on request.

Kimray reserves the right to modify or improve the designs or specifications of such products at any time without prior notice.

©2015 Kimray Inc.

Page left blank

Contents

A Before you start.....	5	16 Adjusting Screw.....	23
A1 Scope.....	5	17 Guage.....	24
A2 Introduction.....	5		
A3 Description.....	5		
A4 Maintenance.....	5		
A5 Changes and Updates.....	5		
A6 Special Tools and Equipment.....	6		
A7 Orientation.....	7		

TESTING

18 Flow Direction, Adjusting Screw, Check for Leakage.....	25
---	-----------

INSTALLATION

1 Installation.....	8
2 Start-up and Test.....	8

DISASSEMBLY

3 Adjusting Screw, Bonnet.....	9
4 Spring Plate, Spring, Nut.....	9
5 Housing, Lower Housing Removal.....	10
6 Lower Seat.....	11
7 Upper Housing.....	11
8 Lower Housing Body.....	12

INSPECTION

9 Inspection & Cleaning.....	14
---	-----------

ASSEMBLY

10 Lower Housing Assembly.....	16
11 Diaphragm.....	18
12 Upper Housing, Lower Seat.....	19
13 Housing, Lower Housing Assembly.....	20
14 Spring, Bonnet.....	21
15 Breather Plugs.....	22

A Before you start



CAUTION:

The instructions provided herein should be completely reviewed and understood before operating or repairing this equipment. All **CAUTION** and **WARNING** notes must be strictly observed to prevent personal injury or equipment damage.

A1 Scope

Do not install, operate, or maintain a pressure regulator without being fully trained and qualified with the Kimray installation, operation and maintenance manual.

To avoid personal injury or property damage, it is important to carefully read, understand, and follow all the contents of this manual, including all safety cautions and warnings.

If you have any questions about this manual, contact your Kimray applications support group before proceeding.

A2 Introduction

This repair manual contains information for the OBP, OBPV, OPR, OPRV Pressure Regulators.

A3 Description

The Kimray Gas Pilot operated Pressure Regulator combines a pressure Pilot with a Control Valve. Regulators perform one of three functions. The back Pressure Regulator maintains a constant upstream pressure, the pressure reducing regulator maintains a constant downstream pressure and the differential Pressure Regulator maintains a constant difference between upstream and downstream pressure.



CAUTION:

When ordered, the Pressure Regulator configuration and construction materials were selected to meet specific pressure, temperature, pressure drop and fluid conditions. Since some Body / trim material combinations are limited in their pressure drop and temperature ranges, do not subject the Pressure Regulator to any other conditions without first contacting the Kimray Inc, sales office or a sales / applications representative.



WARNING:

DO NOT exceed the maximum pressure specified on the namePlate. Under no circumstances should the regulator supply pressure ever exceed the maximum psig.

A4 Maintenance

Maintenance should be performed on a regular basis. Initial intervals of 12 months is recommended. The maintenance interval may increase or decrease depending on changing application environments. The valve can be repaired without being removed from the piping.

Related Publications

The following publications are applicable for the regulator

Number	Type	Title
--------	------	-------

See catalog Section A for product pages.

Abbreviations / Acronyms

The abbreviations that follow are used in this manual.

Term

Definition

OBP	Ouncers Back Pressure
OBPV	Ouncers Back Pressure to Vacuum
OPR	Ouncers Pressure Reducing
OPRV	Ouncers Pressure Reducing Vacuum

Commonly Replaced Parts

- Trim Set
- Diaphragm
- O-Ring

Occasional Replacement Parts

- Body
- Spring

A5 Changes and Updates



NOTE:

To prevent galling or seizing at assembly level for straight threads Kimray recommends using a nickel impregnated paste. For other threads use a nickel impregnated PTFE thread sealant tape.

MODEL: Back Pressure to Atmosphere
Installation, Operation & Maintenance Guide

SPECIAL TOOLS AND EQUIPMENT

Kimray Seat Wrenches
and Stem Guides

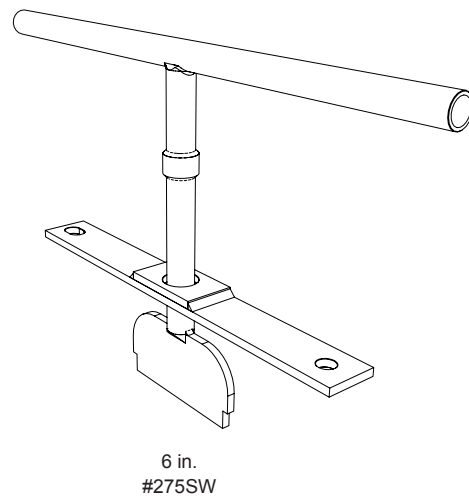
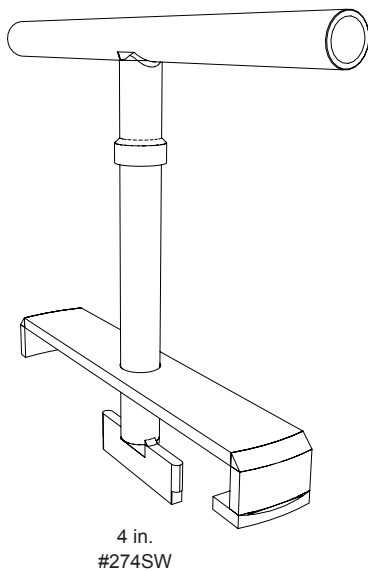
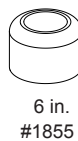
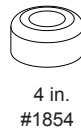
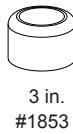
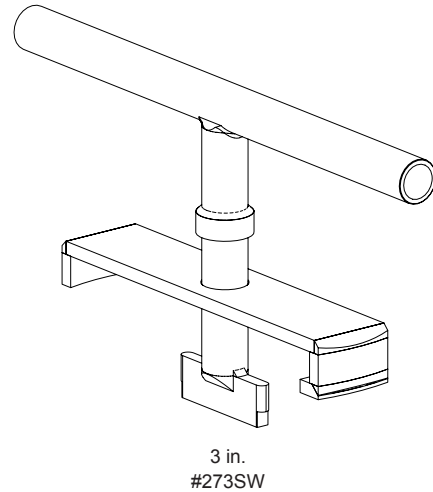
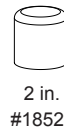
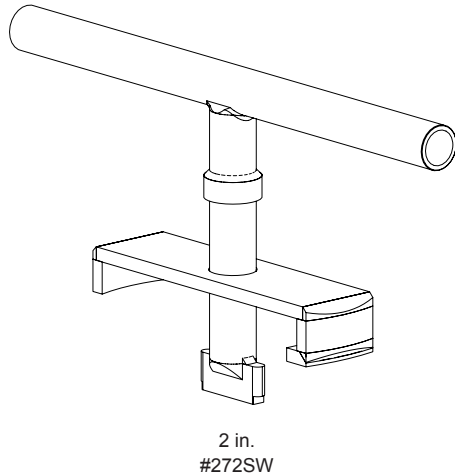

Power Tube Brush			
Diameter	Wire Size	Length	Stem Diameter
1/4 in.	0.004 in.	3 1/2 in.	1/8 in.
3/4 in.	0.006 in.	3 1/2 in.	1/4 in.
1 1/4 in.	0.008 in.	3 1/2 in.	1/4 in.

NOTE: Standard Non-Kimray Tube Brushes



Tip:

Kimray recommends using the above special tools and equipment for disassembly, assembly and new part replacements.

ORIENTATION

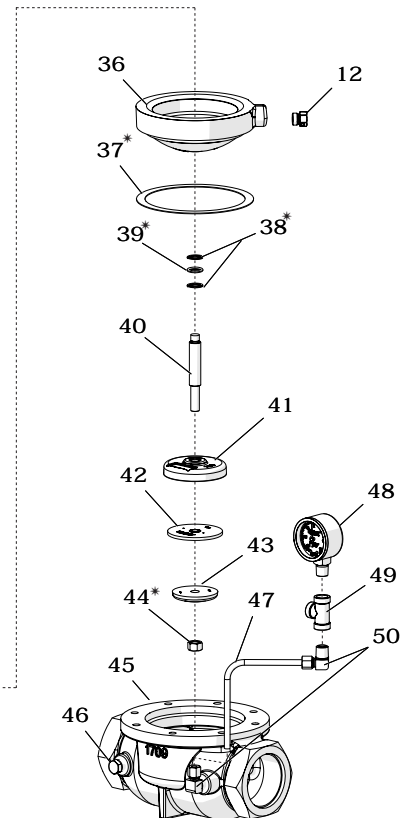
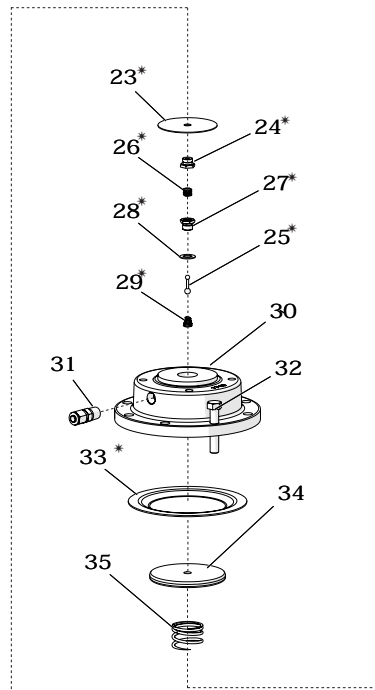
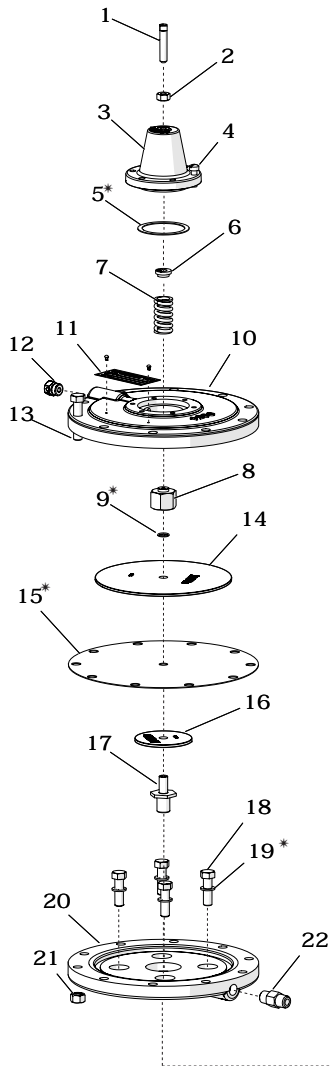

A7

* Recommended spare parts and stocked as repair kits

Item	Description	Qty
1	Adjusting Screw	1
2	Nut	1
3	Bonnet	1
4	Screw	6
5	Gasket *	1
6	Spring Plate	1
7	Spring	1
8	Nut	1
9	O-Ring *	1
10	Housing	1
11	Name Plate	1
12	Breather Plug	1
13	Screw	10
14	Diaphragm Plate	1
15	Diaphragm *	1
16	Lower Diaphragm Plate	1
17	Stem	1

See catalog section A for additional information

Item	Description	Qty
18	Screw	4
19	Gasket *	4
20	Lower Housing	1
21	Nut	10
22	Nipple	1
23	Diaphragm *	1
24	Seat *	1
25	Pilot Plug *	1
26	Spring *	1
27	Seat *	1
28	Gasket *	1
29	Spring *	1
30	Upper Housing	1
31	Connector	1
32	Screw	8
33	Diaphragm *	1

Item	Description	Qty
34	Plate	1
35	Spring	1
36	Lower Housing	1
37	Gasket *	1
38	Back Up *	2
39	O-Ring *	1
40	Stem	1
41	Seat Disc	1
42	Seat	1
43	Ratio Plug	1
44	Nut *	1
45	Body	1
46	Plug	1
47	Tubing	1
48	Gauge	1
49	Tee	1
50	Elbow	2

Kimray reserves the right to modify or improve the special tools and equipment designs or specifications at anytime without notice.

MODEL: Back Pressure to Atmosphere Installation, Operation & Maintenance Guide

1 Installation

Before installing the Pressure Regulator, inspect it for shipment damage and for foreign material that may have collected during shipment. Inspect the openings in the valve and clean the pipe lines to remove scale, chips and debris.

Verify all pressure connections are tight before pressurizing the system.

1. Install the regulator with the arrow on the Body pointing in the direction of flow. The arrow indicates that the direction of flow and will not necessarily prevent flow in the opposite direction.
2. Install the regulator using good piping practice. For flanged bodies use a suitable Gasket between the Body and the pipeline flanges. For threaded (NPT) bodies, use TFE tape or pipe thread sealant on external pipe threads.

! NOTE:

Never stand directly over or in front of a regulator when the system is pressurized. The regulator could suddenly open, blowing debris onto the face and eyes. Check all vents periodically to be certain they are clear.

If a vent should become blocked the regulator could lose control.

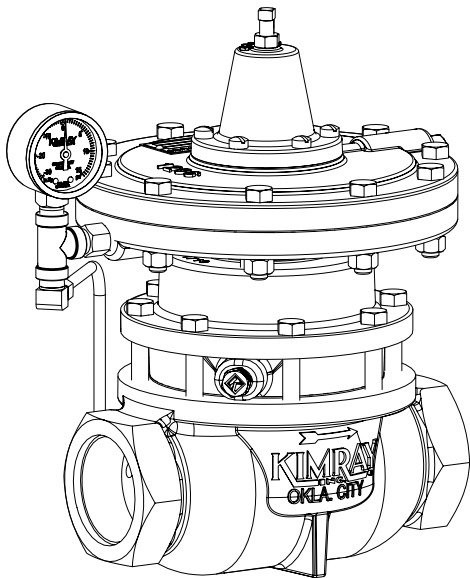

Fig. 1-1

Back Pressure Regulator:

Remove the tapered plug after the regulator is installed. The plug only prevents the oil from leaking out of the regulator during shipment and installation.

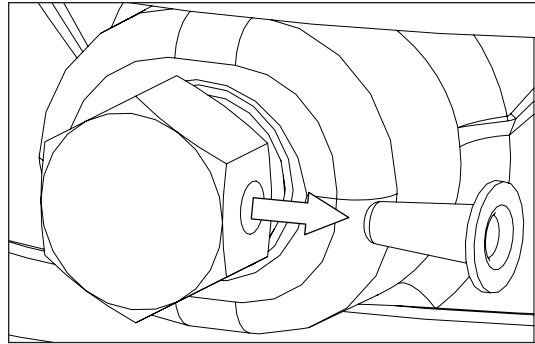

Fig. 1-2

! WARNING:

Regulators rated to 175 psig (12 bar), if hazardous or flammable gas is being conveyed and the regulator is in an enclosed area, personal injury or property damage could result from accumulated gas being released through the vent. To avoid potential risk, provide adequate ventilation or pipe away the vented gas.

This does not apply to non venting **NV** models. No gas is vented with **NV**.

2 Start-up and Test

With the installation completed and appropriate relief and check valves installed and set, slowly open the upstream and downstream shutoff valves. Turn the Adjusting Screw out and then back in until you feel it begin to meet resistance as it engages the Spring.

Back Pressure Regulator.....Open

As you turn the Adjusting Screw clockwise, the set point pressure will increase.

! WARNING:

Before any service, be certain that the valve is fully isolated and that all pressure upstream and downstream has been relieved. Use bypass valves or fully shut off the process. Be sure that any operating or instrument gas lines has been Disconnected. Never assume that a check valve is fully blocking the downstream line. Never tighten any fitting or the main connections to the regulator while there is pressure on the line. A leaking valve indicates that service is required. Failure to take the valve out of service immediately may create a hazardous condition.

DISASSEMBLY

3 Adjusting Screw, Bonnet

Remove both Adjusting Screw and Nut. (not shown)

Wrench loose six Screws and remove Bonnet.

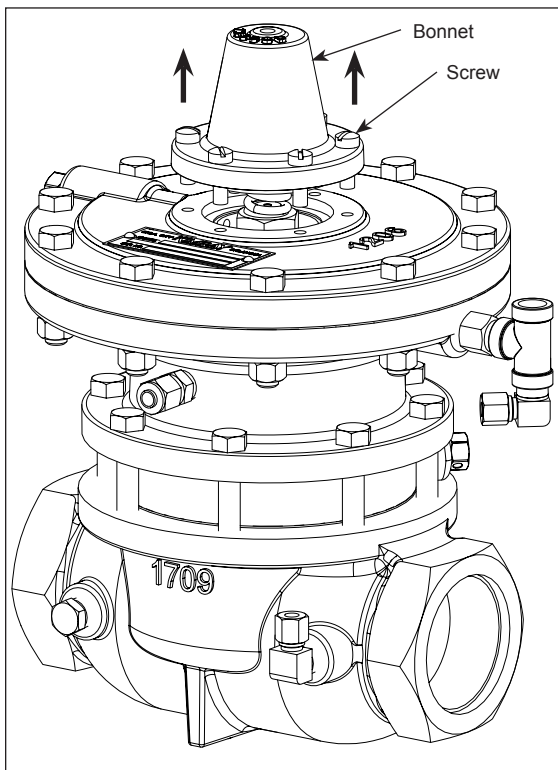

Fig. 3-1

4 Spring Plate, Spring, Nut

Remove Spring Plate.

Remove Spring.

Remove Nut.

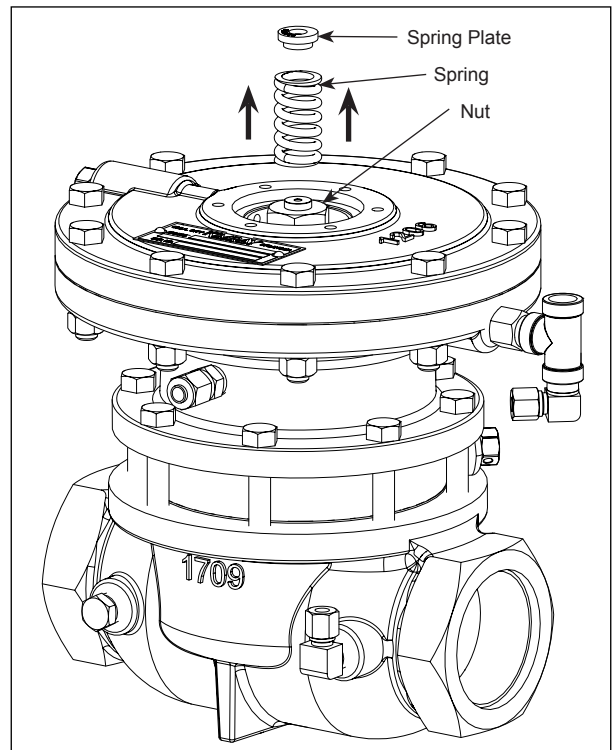

Fig. 4-1

DISASSEMBLY

5 Housing, Lower Housing Removal

Loosen the top Bolts to remove the Housing.
(not shown)

Pry Housing loose with a flat head screwdriver.
See Fig. 5-1

Remove the Spring and Plates. See Fig. 5-2

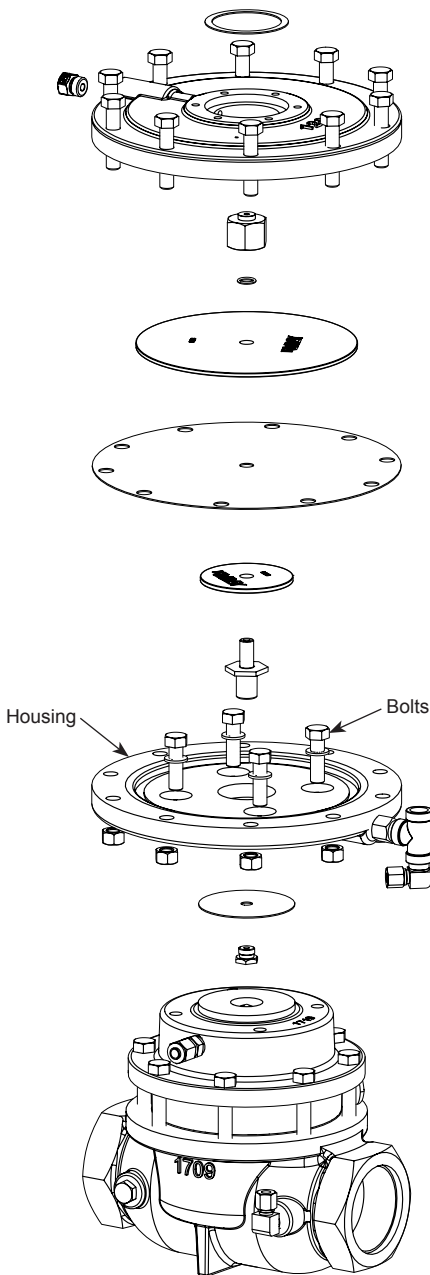

Fig. 5-1

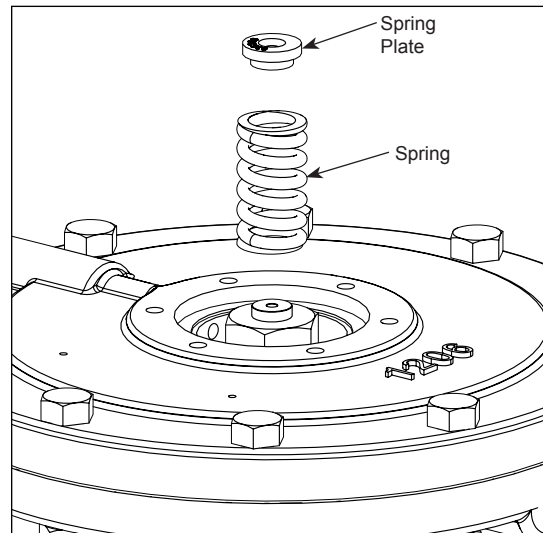

Fig. 5-2

DISASSEMBLY

6 Lower Seat

Remove Lower Seat with a socket.
See Fig. 6-1

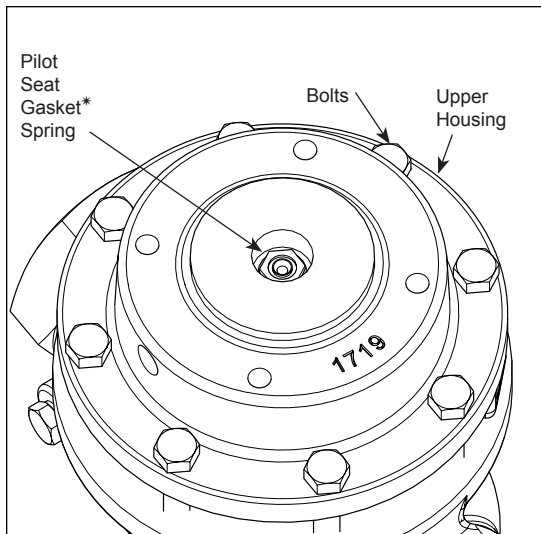

Fig. 6-1

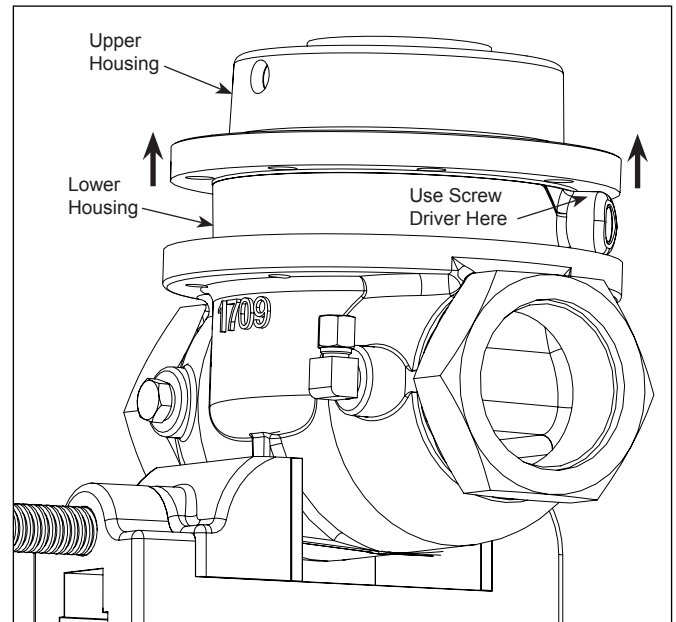

Fig. 7-1

7 Upper Housing

Remove the Bolts on the Upper Housing. Use a flat head screw driver and wedge between Upper Housing Breather Hole and Nipple on Lower Housing. Tap the screw driver with a hammer and remove the Upper Housing. See Fig. 7-1

Use a socket to remove the Breather Plug.

Remove Diaphragm. See Fig. 7-2

Use a flat head screw driver and wedge between Breather Hole and Nipple (not shown) on Housing. Tap the screw driver with a hammer and remove the Lower Housing.

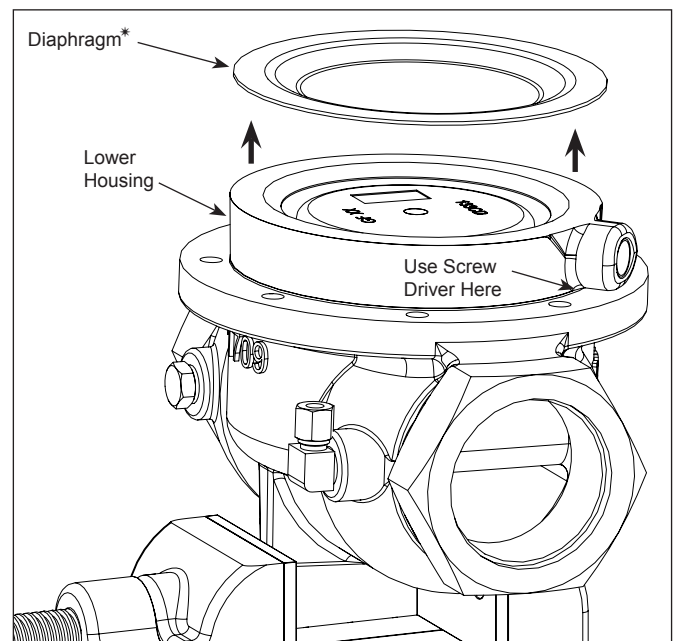

Fig. 7-2

MODEL: Back Pressure to Atmosphere
Installation, Operation & Maintenance Guide

DISASSEMBLY

8 Lower Housing, Body



NOTE:

Be sure the oil has been drained from the Lower Housing.

Use a flat screw driver and wedge it between Breather Hole Nipple in Lower Housing and Body. Tap screw driver with a hammer and remove Lower Housing. See Fig. 8-1

Flip Lower Housing over and remove the Diaphragm Plate. See Fig. 8-2

Remove the Stem along with the Disc, Seat, Ratio Plug and Lock Nut. See Fig. 8-3

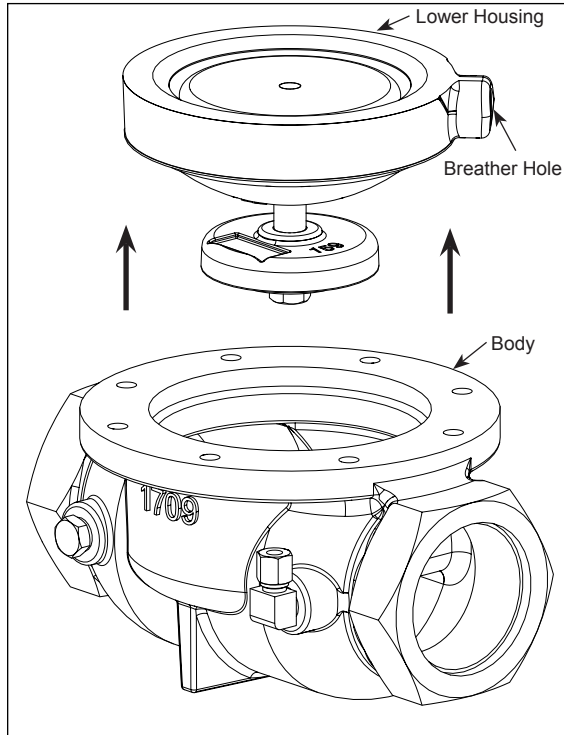

Fig. 8-1

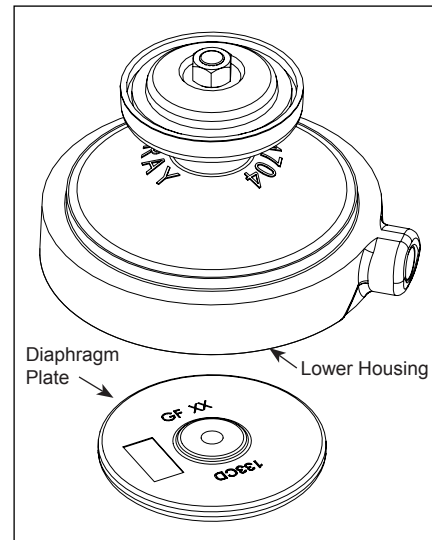

Fig. 8-2

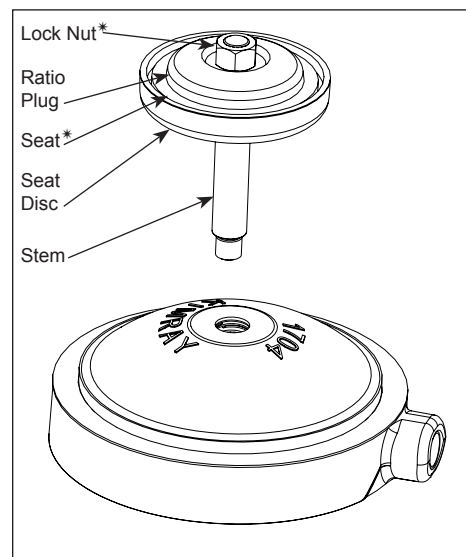

Fig. 8-3

DISASSEMBLY

Insert brass jaws on vice (not shown). Tighten the Stem in the vice and remove Lock Nut. See Fig. 8-4

Remove the Seat and Ratio Plug from the Seat Disc.

Remove the O-Ring and two Back Ups from the Lower Housing. See Fig. 8-5



CAUTION:

Use putty knife to remove the Gasket from the Body. See Fig. 8-6

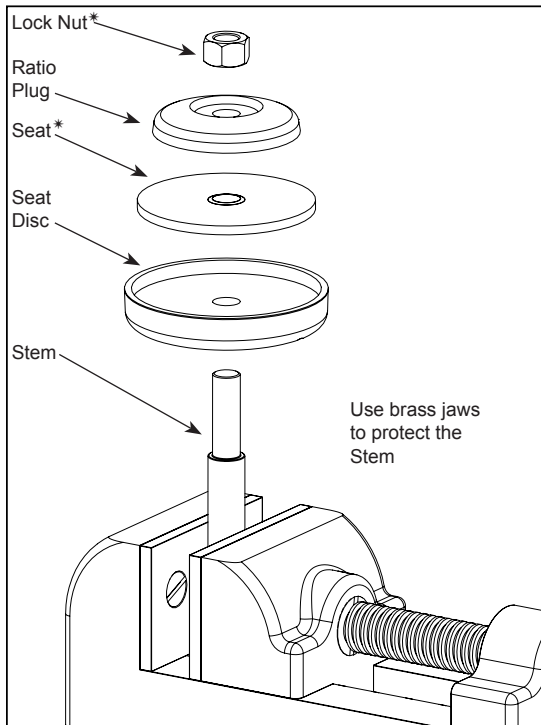

Fig. 8-4

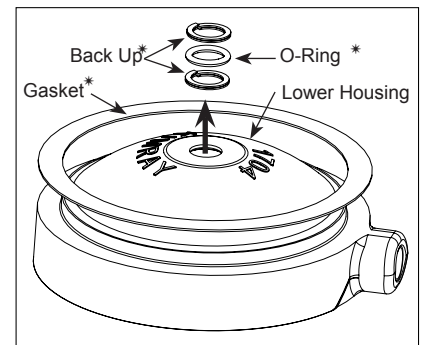

Fig. 8-5

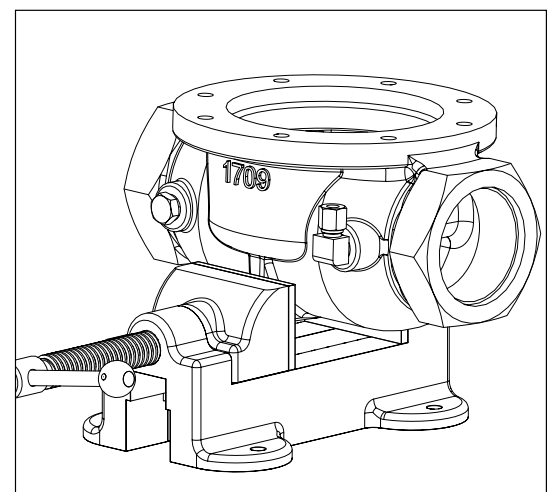

Fig. 8-6

INSPECTION

9 Inspection & Cleaning

⚠ NOTE:

Nicks or fragments of Gasket material can cause misalignment on the Body surface. This can be repaired by using a flat file. See Fig. 9-1

Repair:

If there are dings in the Lower Housing.

Cleaning:

Wire brush both the Breather Hole and the Lower Housing.

Use an air nozzle to blow out the particales from inside the Lower Housing.

See Fig. 9-2

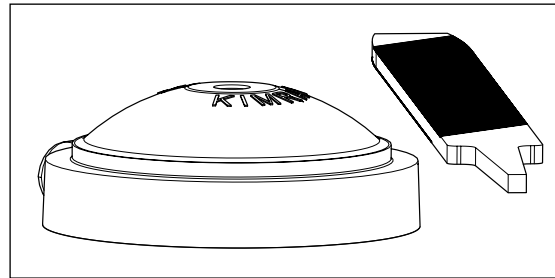

Fig. 9-1

⚠ NOTE:

Roll the Stem on a flat surface to check for straightness
See Fig. 9-3

Replace:

If Stem is bent.

⚠ NOTE:

If light scratches or galling is present, repair the Stem by sanding the surface with a 220 grit or finer sand paper. If repair is not possible Kimray recommends replacement.

Repair:

If Stem surface shows light scratches.

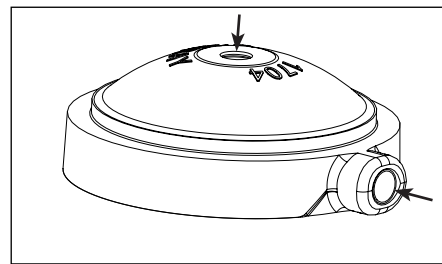

Fig. 9-2

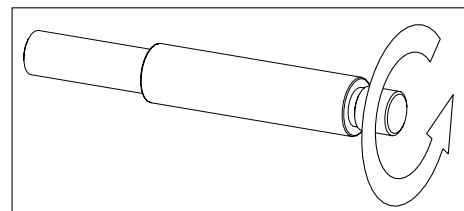

Fig. 9-3

⚠ NOTE:

Use putty knife to remove the Gasket from the flange face. See Fig. 9-4

Cleaning:

Use an air nozzle to clear any particles on flange face.

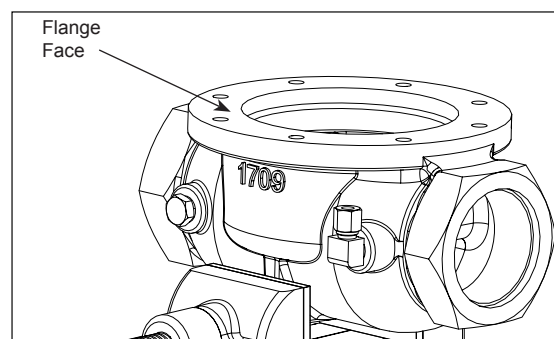

Fig. 9-4

INSPECTION

Inspect the Removable Seat for excessive wear or scratches. If the Seat is in good shape leave it in place. Removing the Seat could result in additional damage.

If the Seat needs to be replaced, insert the Seat wrench and use a rubber hammer to break the Seat loose.



NOTE:

For larger regulator sizes, the Seat might not easily come apart. If this is the case try the following. See Fig. 9-5



CAUTION:

Tap the handle with a shop hammer. Insert a cheater pipe over the handle for additional leverage. Heat the Seat with a torch if necessary for removal.



NOTE:

Lower pressure valves **DO NOT** have a Removable Seat.

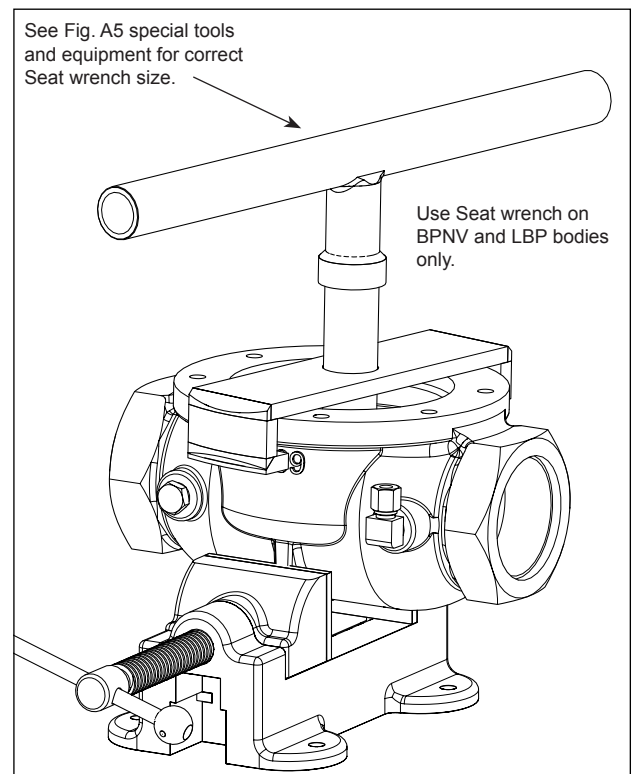

Fig. 9-5

ASSEMBLY

10 Lower Housing Assembly

Insert the first Back Up in the Lower Housing groove. The Back Up will spiral into the groove.

Using a narrow screw driver, insert the O-Ring on top of the Back Up.

Insert the second Back Up in the Lower Housing groove.

Use a brush to grease Back Ups and O-Rings. See Fig. 10-1

Before assembling, apply primer and Blue Loctite™ to short end of the Stem. Hand tighten the Stem into the machined side of the Diaphragm Plate. See Fig. 10-2

To prevent shearing the O-Ring, insert the Stem Guide on Stem with the radius side on top. See Fig. 10-3

Place the Lower Housing onto the Stem. Remove the Stem Guide from the Stem. See Fig. 10-4

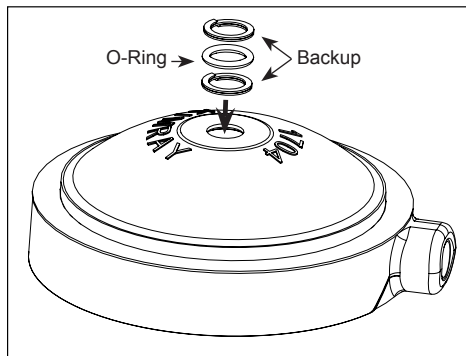

Fig. 10-1

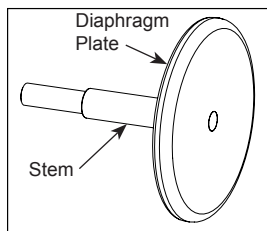

Fig. 10-2

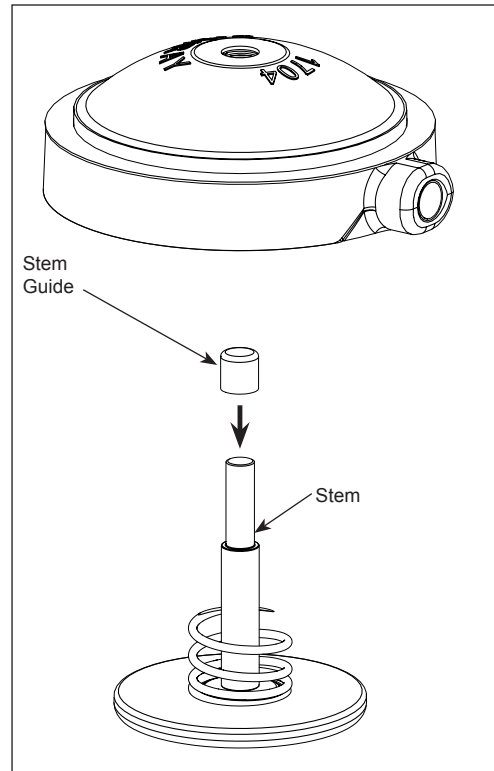

Fig. 10-3

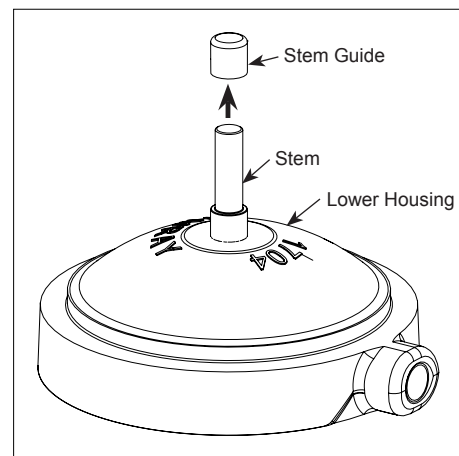

Fig. 10-4

ASSEMBLY

Place the Seat Disc on the Stem.

Insert the Seat into the Seat Disc.

Insert the Ratio Plug on top of the Seat.
See Fig. 10-5

Apply all purpose grease to threads of Stem and hand start the Lock Nut threads.

Hold the Seat Disc in one hand and use a socket to tighten the Lock Nut. Stop when you start to feel the Seat Disc turning in your hand. **DO NOT OVER TIGHTEN**, but you do not want the Disc spinning on the Stem.
See Fig. 10-6

Apply all purpose grease to the Lower Housing shoulder.
Place the Gasket on the Lower Housing shoulder.

Apply all purpose grease the top side of the Gasket.
See Fig. 10-7

Insert the Lower Housing into the Body.
Make sure the Breather Hole aligns with the back side of the flow arrow.
See Fig. 10-8

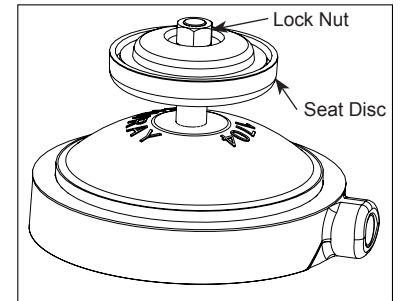

Fig. 10-6

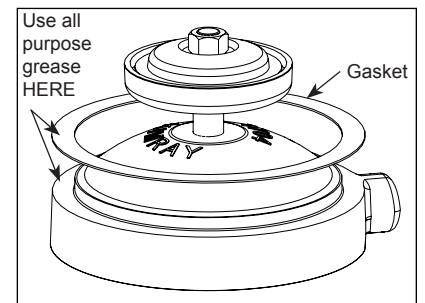

Fig. 10-7

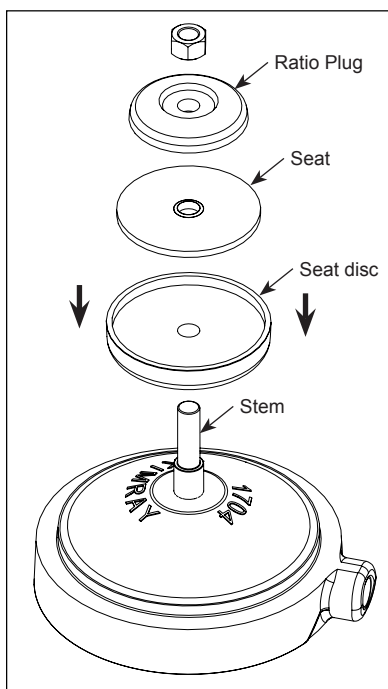

Fig. 10-5

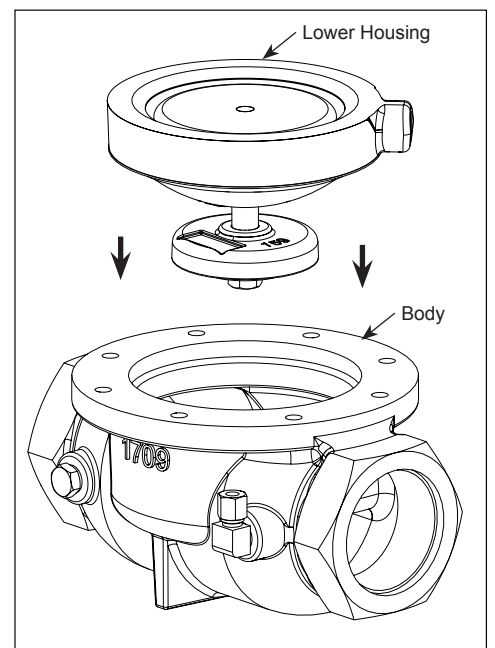

Fig. 10-8

MODEL: Back Pressure to Atmosphere
Installation, Operation & Maintenance Guide

ASSEMBLY

For the orientation of Lower Housing boss to Body. See Fig. 10-9

Add all purpose oil to the Lower Housing until the oil is above the lower communication hole and below the upper communication hole. See Fig. 10-10 & 10-11

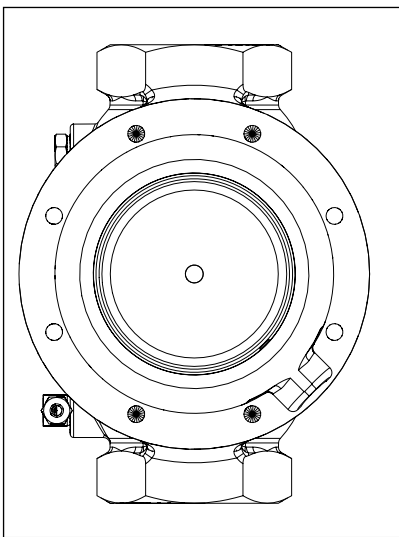

Fig. 10-9

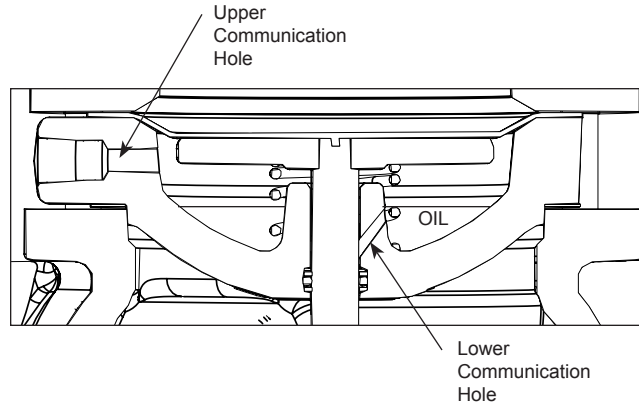

Fig. 10-11

11 Diaphragm

Install Diaphragm onto Lower Housing assembly.
See Fig. 11-1



NOTE:

Be sure Diaphragm is placed in a 'bowl' position inside the Lower Housing.

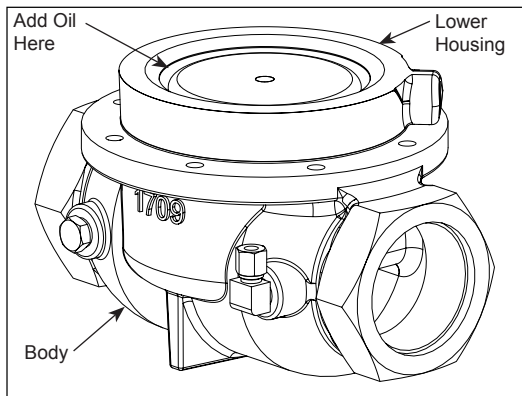

Fig. 10-10

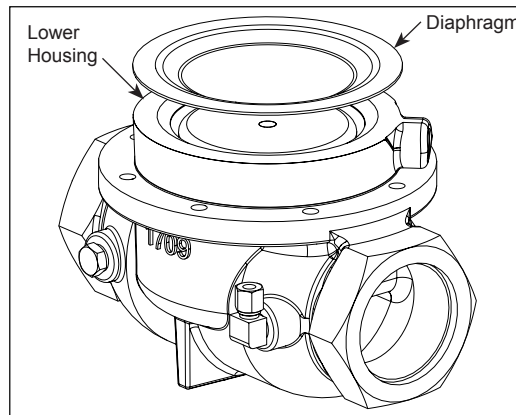

Fig. 11-1

ASSEMBLY

12 Upper Housing, Lower Seat

Place the Upper Housing on top of the Lower Housing. Start all Bolts at least three rotations into Body and run one Bolt down to the shoulder. Hand tighten the remaining Bolts using the torque star pattern. See Fig. 12-1

Align the Breather Hole between outlet holes in Body. See Fig. 12-2

Install Gasket and Lower Seat into the Upper Housing. DO NOT OVER TIGHTEN. See Fig. 12-3

! NOTE:

Make sure you tighten the Bolts in a criss-cross pattern to avoid any miss alignment. For 2 in., 3 in., and 4 in. tighten Bolts to 25-30 ft/lbs torque.

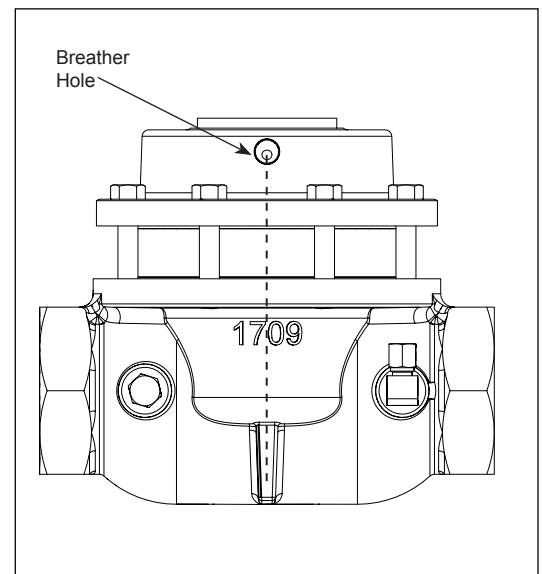

Fig. 12-2

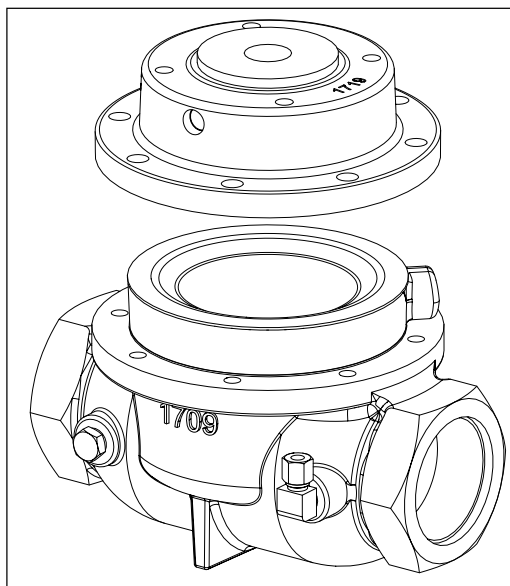

Fig. 12-1

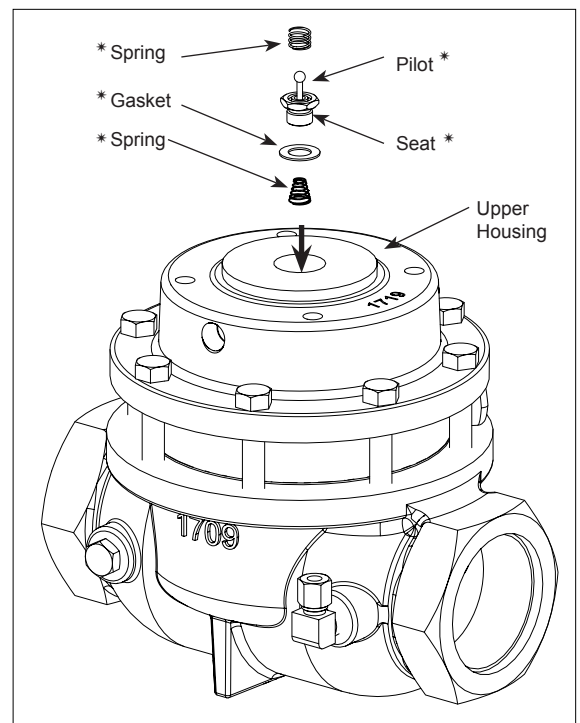

Fig. 12-3

ASSEMBLY

13 Housing, Lower Housing Assembly

Place the Upper Housing on top of the Lower Housing. Start all Bolts at least three rotations into Body and run one Bolt down to the shoulder. Hand tighten the remaining Bolts using the torque star pattern.

Align the Breather Hole between outlet holes in Body.

Install Gasket and Lower Seat into the Upper Housing. **DO NOT OVER TIGHTEN.**

NOTE:

Make sure you tighten the Bolts in a criss-cross pattern to avoid any miss alignment. For 2 in., 3 in., and 4 in. tighten Bolts to 25-30 ft/lbs torque.

Apply primer and blue Loctite™ to both ends of Nipple and thread one end into Filter and the other end into pressure port of Diaphragm Housing.

NOTE:

Clamp Filter Body into the vice using brass jaw (not shown) and tighten

Insert screens (rough edge up) in the Filter.

Place O-Ring onto the Filter Cap.

Hand start Filter Cap into Filter Body and tighten with a wrench.

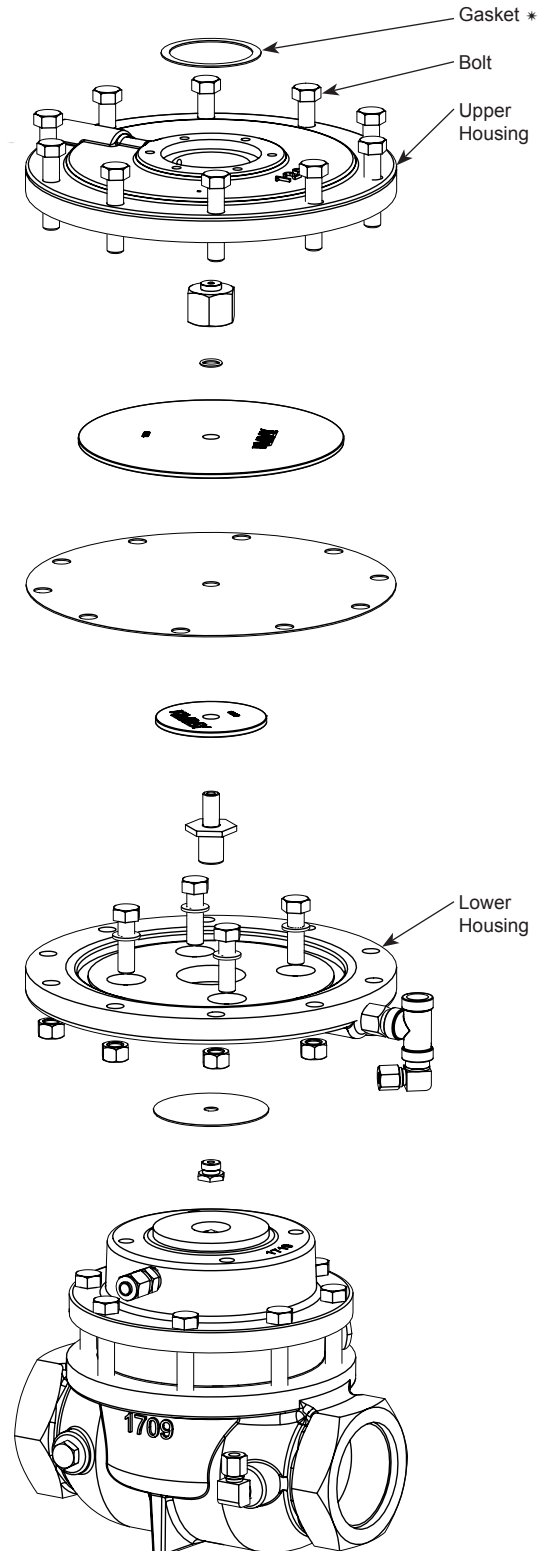

Fig. 13-1

ASSEMBLY

14 Spring, Bonnet

Apply all purpose grease on the top surface of the Spring Plate and place the Spring Plate on top of Spring. See Fig. 14-1

Place the Spring on top of the Nut.

Install Spring Plate on top of Spring. Apply all purpose grease to bevel of Spring Plate.

Install the Bonnet on top of the Spring assembly.

Insert Bolts and tighten with a speed wrench. See Fig. 14.2



NOTE:

Tighten Screws in a criss-cross pattern to avoid any miss alignment. Tighten Bolts to a snug fit.

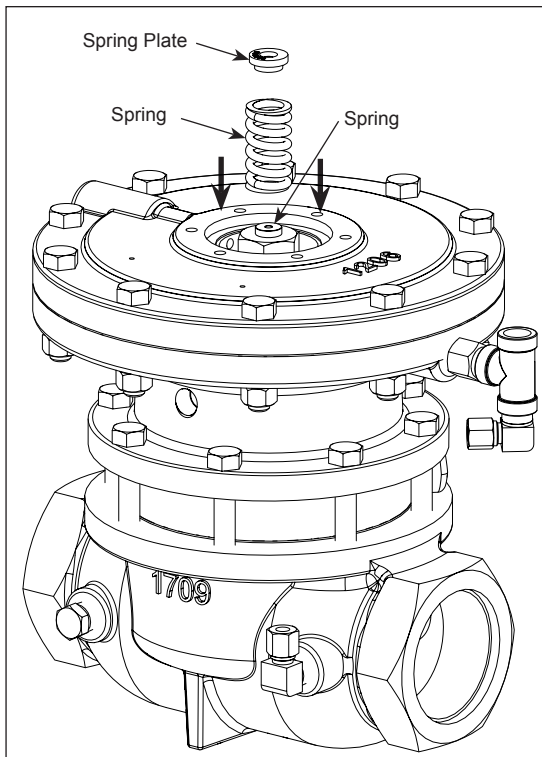

Fig. 14-1

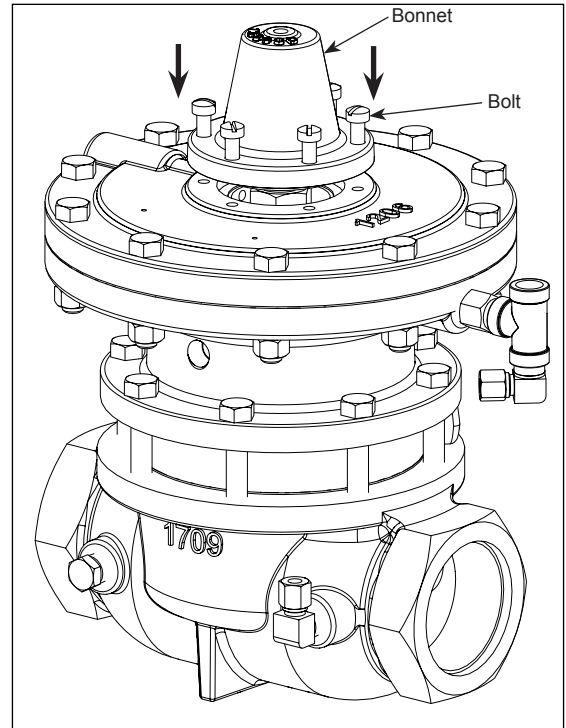

Fig. 14-2

ASSEMBLY

15 Breather Plugs



NOTE:

Apply blue Loctite™ to Breather Plugs and hand start into both Upper Housing and Lower Housing bosses.

Insert Breather Plug in Upper Housing. See Fig. 15-1

Insert Breather Plug in Lower Housing. See Fig. 15-2

The Breather Plug hole should stop in the five to eight o'clock position.

Install small red plug into the Breather Hole of the Lower Housing Breather Plug. (Red plug not shown) and remove after installation. See Fig. 15-2

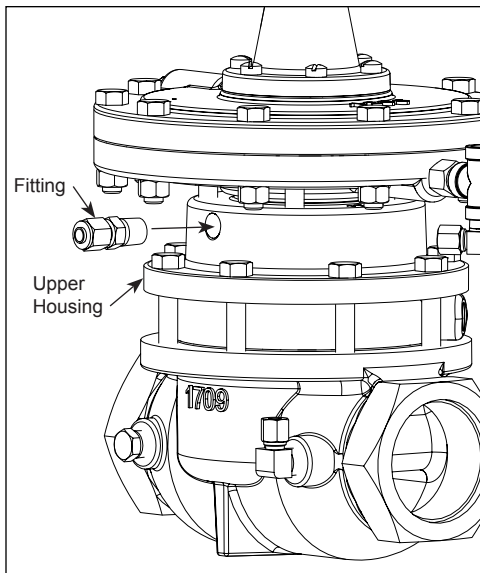

Fig. 15-1

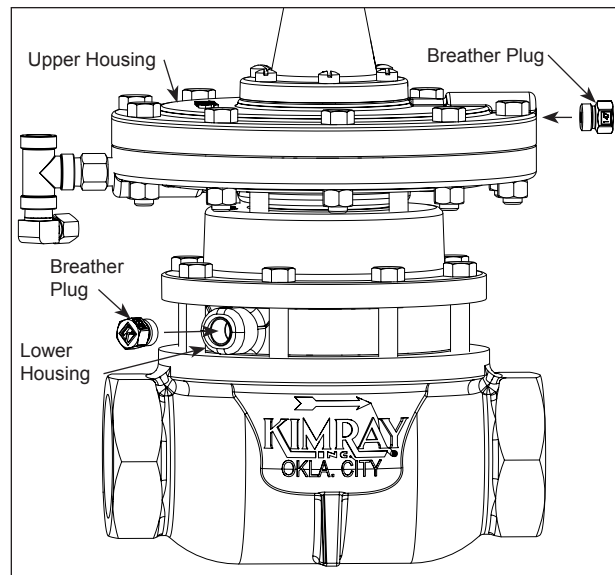

Fig. 15-2

ASSEMBLY

16 Adjusting Screw, Tubing

NOTE:

Apply all purpose grease to the first few threads of the Adjusting Screw.

Thread the Adjusting Screw with Nut, Washer and Packing Seal (Not Shown) on top of the Bonnet.
See Fig. 16-1

Connect the tubing from the upstream communication hole to the Tee. See Fig. 16-2

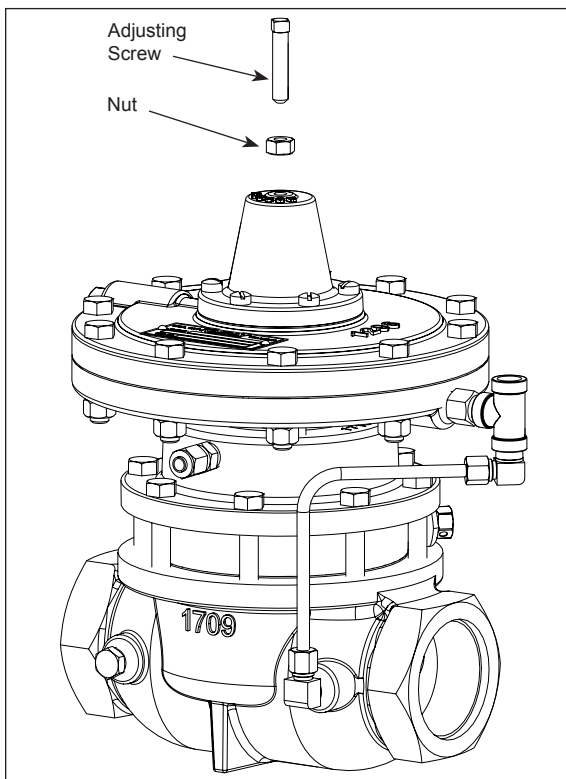

Fig. 16-1

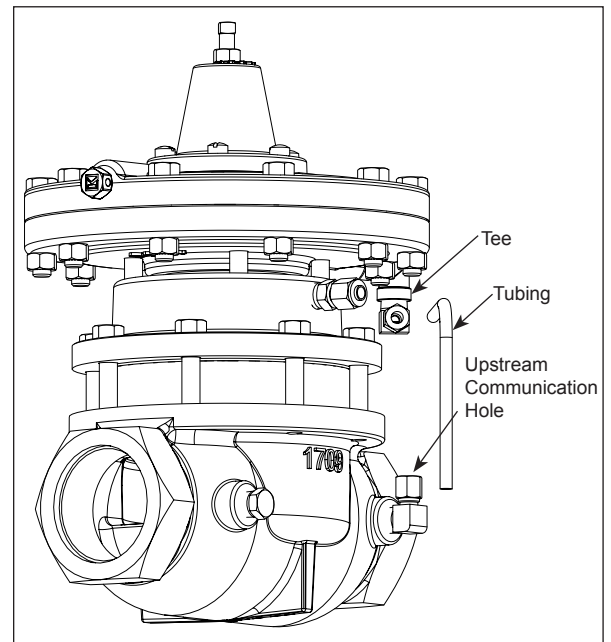

Fig. 16-2

MODEL: Back Pressure to Atmosphere
Installation, Operation & Maintenance Guide

ASSEMBLY

17 Gauge

Verify the Needle is in the correct position.



NOTE:

Apply Blue Loctite™ to the Gauge threads.

Thread the Gauge into the Tee and tighten with an adjustable wrench. See Fig. 17-1

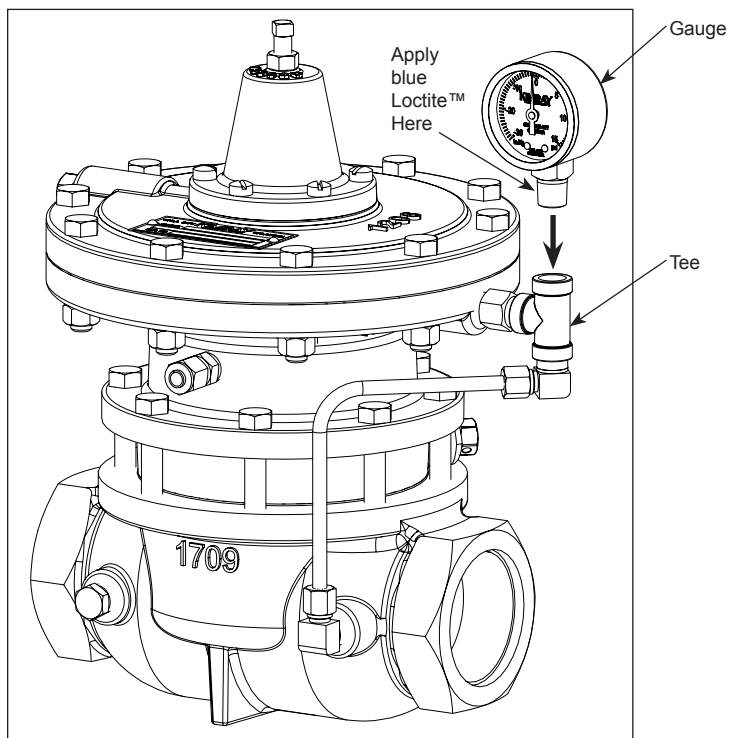

Fig. 17-1

TESTING

18 Flow Direction, Adjusting Screw, Check For Leakage

Flow Direction

Make sure the air is flowing from upstream to downstream. Regulators have an arrow showing the direction of flow.

Adjusting Screw

Use an adjustable wrench to run the Adjusting Screw all the way down.

Check for Leakage

Turn supply air off and make sure the Gauge is holding pressure on the upstream side. If Gauge falls off then you have leakage.

Check if any leakage is coming out the downstream side.

Spray soaped water on Tubing, Housings, Breather Plugs and Plugs. The identification of leakage will be noted if any bubble shows up.

Regulator Test

Once no leakage is detected, close upstream flow.



NOTE:

Make sure the regulator holds various levels of pressure. (100 psi down to 5 psi by turning the Adjusting Screw out).

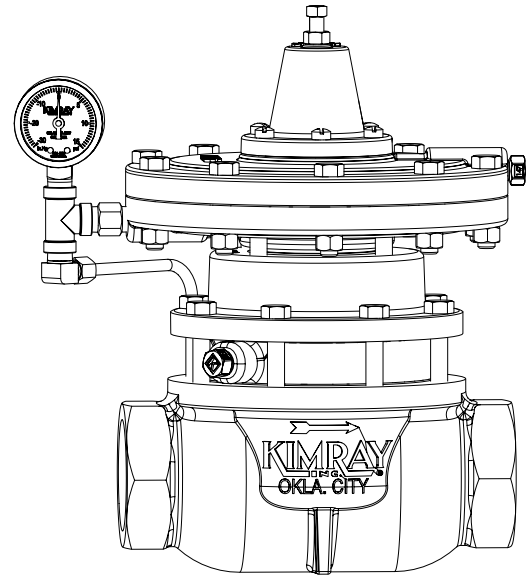

Fig. 18-1

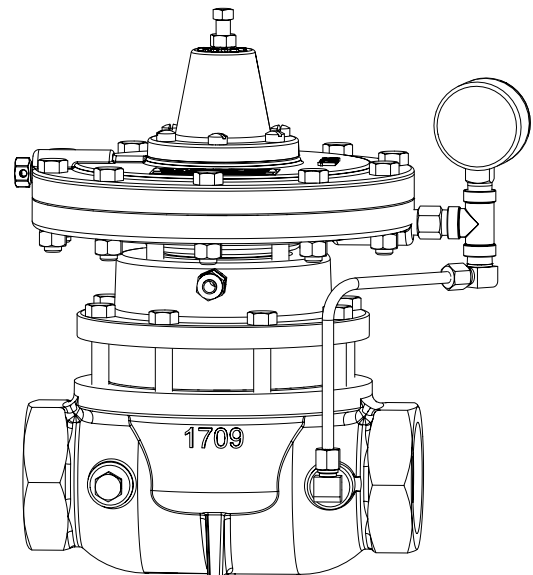

Fig. 18-2

Troubleshooting		
Problem	Possible Cause(s)	Possible Solution
Regulator appears to be stuck in ON position.	Stopper has not been removed from Breather Plug in Lower Housing. (BP Regulator)	Remove the stopper.
Regulator leaks through to downstream.	Over tightened Seat Nut can cause Seat to bulge and leak.	DO NOT OVER TIGHTEN Seat.
Pilot bleeds gas continuously.	The Pilot plug Seat may be dirty.	Clean the Pilot plug Seat.
Minimum set point cannot be set.	Bonnet Screws are over tightened.	DO NOT OVER TIGHTEN Bonnet Screws.
Regulator will not open.	A Pilot Seat may be loose. (BP Regulator)	Tighten the Pilot Seat.
Regulator will not close.	A Pilot Seat may be loose. (PR Regulator)	Tighten the Pilot Seat.

PRESSURE REGULATORS

*MODEL: Back Pressure to Atmosphere
Installation, Operation & Maintenance Guide*



Page left blank



PRESSURE REGULATORS

*MODEL: Back Pressure to Atmosphere
Installation, Operation & Maintenance Guide*

Kimray is an ISO 9001- certified manufacturer.
Kimray quality assurance process maintains strict controls
of materials and the certification of parts used in the Kimray severe service control valve.

Please visit our website for up to date product data www.Kimray.com

WHO WE ARE

Kimray designs and manufactures oil and gas control products. Based on more than 65 years of pioneering product development, we provide products and services that are reliable, smart and inventive. We generate meaningful solutions by staying curious and engaging in customers' needs. Our product ideas are fueled by a deep desire to make a difference that is both personal and unique to the customer.

We have made it our life's work to provide products and services that are positively impactful. Through the years, this pursuit has built strong relationships. Our customers have known that buying from Kimray is about much more than the product. The relationships between Kimray representatives and our customers extend from before the sale through the life of the product. Those relationships, along with quality Kimray products, are the result of a company striving for excellence for our customers, our company and our community.

Visit Kimray.com to learn more about our company and the products we create.



Kimray.com

