

APPLICATION:

Self-contained, pilot-operated regulator designed to regulate ounces (0.5 oz to 2.5 psig) back pressure on a tank and vent to atmosphere when pressure exceeds set point.

FEATURES:

- Tight shut-off
- Single soft seat
- Removable valve seat
- Minimum maintenance
- All internal parts can be removed with valve in line
- Single-point adjustment of setpoint
- Utilizes upstream pressure as actuation pressure
- Efficient 3-way plug accurately maintains setpoint

CERTIFICATIONS:

Canadian Registration Number (CRN):
0C16234.24567890NTY (Ductile)
Kimray is an ISO 9001- certified manufacturer.

CLASSIFICATIONS:

Non-Bleed / Intermittent Vent

UPSTREAM PRESSURE RANGE:

- 1 Inch valves:
Full port 10 psig min. or outside supply source is required
Reduced port 5 psig min. or outside supply source is required
- 2 thru 6 inch valves:
5 psig min. or outside supply source is required

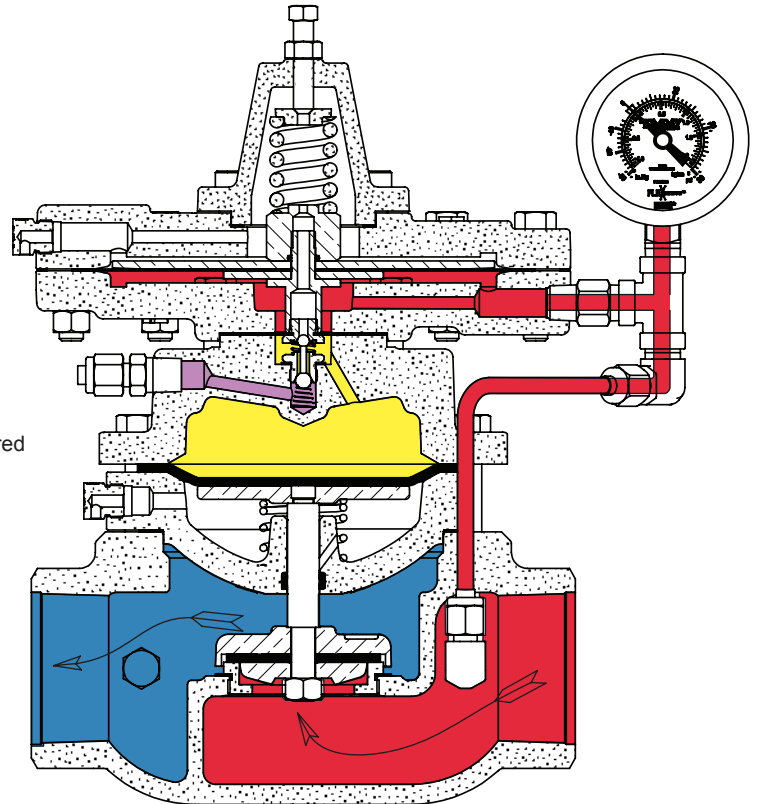
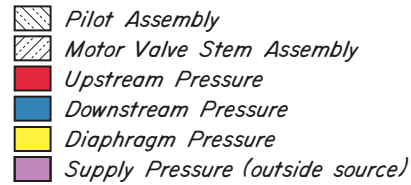

	Standard Configuration Code †	Order Code	Line Size	Connection Type	Oper. Press. psig	Max. W.P. psig ††	Cv	Cf
Ductile	RAB1SADF2S	ABGD20	1"	NPT	10-300	300	13.2	0.74
	RAB2SADF2S	AAID20	2"	NPT	0-20	300	47.0	0.84
	RAB2ARDF2S	AAJD20		150RF	0-20	250		
	RAB3SADF2S	AALD20	3"	NPT	0-20	300	117	0.75
	RAB3ARDF2S	AAMD20		150RF	0-20	250		
	RAB4SADF2S	AAND20	4"	NPT	0-20	300	210	0.75
	RAB4ARDF2S	AAOD20		150RF	0-20	250		
RAB4ARDF2S	AAPD20	6"	150RF	0-20	250	480	0.75	
Steel	RAB2ARWF2S	AVA20	2"	150RF	10-285	285	117	0.75
	RAB3ARWF2S	AFB20	3"	150RF	10-285	285	210	0.75
	RAB4ARWF2S	AVC20	4"	150RF	10-285	285	480	0.75
	RAB6ARWF2S	AJV20	6"	150RF	10-285	285	480	0.75

NOTES:

- For standard & optional seals, metals, Cf Cv values, material specifications & dimensions see technical data on pages 06:1 - 06:1V
- † For Corrosive service remove last "S" & replace with "C"
- † For KimCoat option remove last "S" & replace with "K"
- † For code builder see page 06:00.3
- †† Max W.P. values based on -20°F to 100°F.

PRESSURE REGULATORS

GAS OUNCES BACK PRESSURE TO ATMOSPHERE W/OUTSIDE SUPPLY
MODEL AB PARTS DRAWING

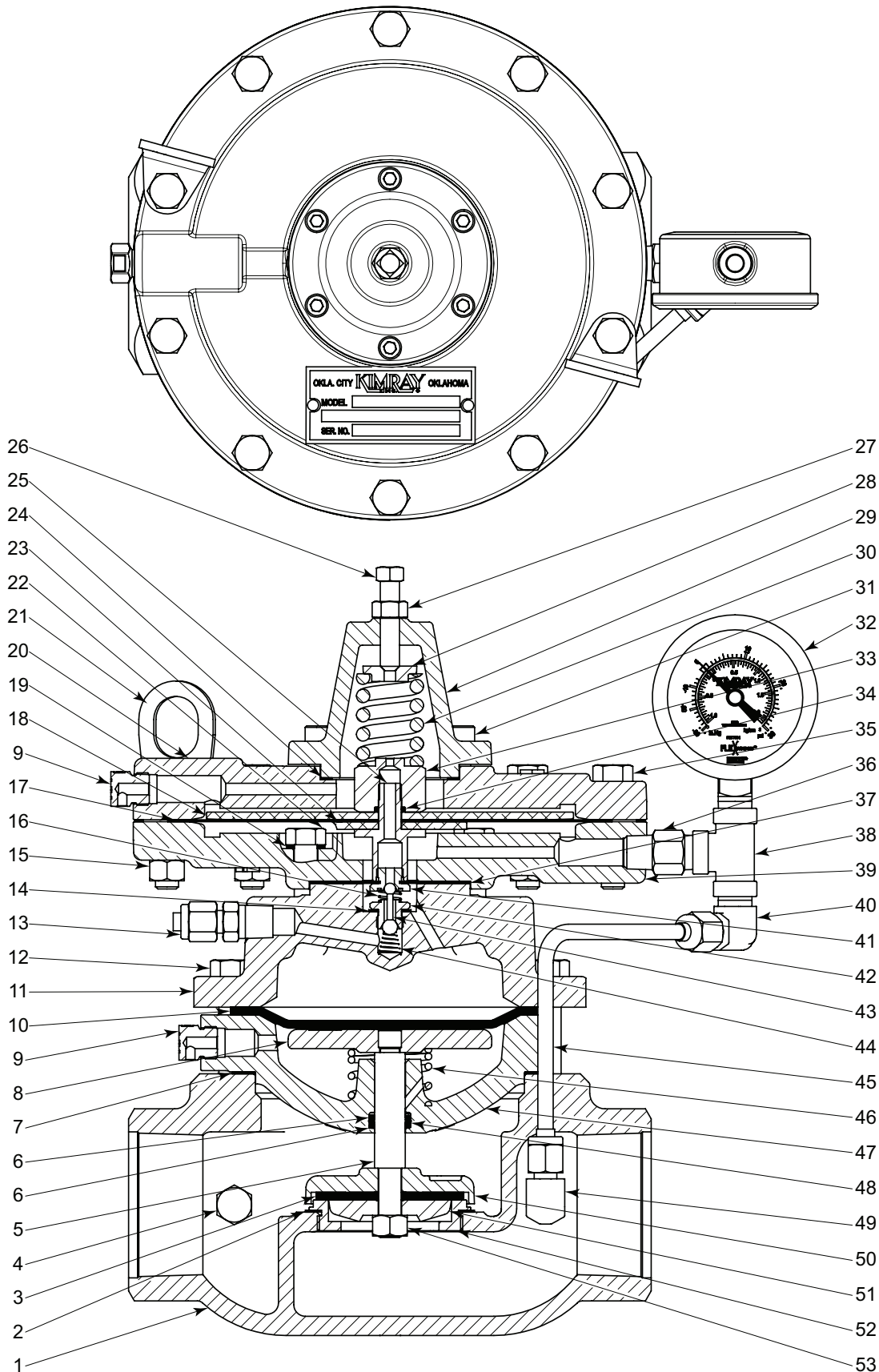

All Pictures shown are for illustration purpose only. Actual product may vary due to product enhancement.



PRESSURE REGULATORS

**GAS OUNCES BACK PRESSURE TO ATMOSPHERE W/OUTSIDE SUPPLY
MODEL AB PARTS LIST**

ITEM	QTY.	DESCRIPTION	PART NUMBER									
			STANDARD				CORROSIVE					
			2 INCH	3 INCH	4 INCH	6 INCH	2 INCH	3 INCH	4 INCH	6 INCH		
1	1	Body										
		NPT Thru	1709	1634	2001	----	1709 ‡	1634 ‡	2001 ‡	----		
		150RF Thru	1913	1914	2002	2466	1913 ‡	1914 ‡	2002 ‡	2466 ‡		
		Grooved Thru	2964	----	----	----	2964 ‡	----	----	----		
2	1	Gasket *	276	277	196	279	276	277	196	279		
3	1	Seat *	164HSN	165HSN	166HSN	167HSN	164HSN	165HSN	166HSN	167HSN		
4	1	Plug	699				699SS6					
5	1	Valve Stem	138	139	140	141	138SS6	139SS6	140SS6	141SS6		
6	2	Back Up *	149T	150T	151T	152T	149T	150T	151T	152T		
7	1	Gasket *	196	197	198	199	196	197	198	199		
8	1	Diaphragm Plate	133	134	135	136	133	134	135	136		
9	2	Vent Plug	147				147SS6					
10	1	Diaphragm *	1706	1640	2015	2140	1706	1640	2015	2140		
11	1	Upper Housing	1719	1636	2003	2177	1719 ‡	1636 ‡	2003 ‡	2177 ‡		
12	(QTY)	Bolt	965 (8)	907(10)	907 (12)	2142 (16)	965 (8)	907(10)	907 (12)	2142 (16)		
13	1	Connector	874				874SS6					
14	1	Gasket *	118				118					
15	10	Nut	241				241					
16	1	Spring *	566				566HAC					
17	1	Diaphragm *	1212				1212					
18	1	Upper Diaphragm Plate	1208				1208SS6					
19	4	Gasket *	242				242					
20	1	Upper Pilot Housing	1206				1206 ‡					
21	2	Lifting Ring	----	7559	----	----	----	7559	----	----		
22	4	Screw	1672				1672SS6					
23	1	Lower Diaphragm Plate	1340				1340SS6					
24	1	Gasket *	1216				1216					
25	1	Stem	2913				2913SS6					
26	1	Adjusting Screw	897				897					
27	1	Nut	922				922					
28	1	Spring Guide	7148S6 (Std.) 636SS6 (Opt. 2.5 & 5 lbs.)				7148S6 (Std.) 636SS6 (Opt. 2.5 & 5 lbs.)					
29	1	Bonnet	1336				1336 ‡					
30	1	Spring	4379 (Std.) 1527 (Opt. 2.5 lbs.) & 3061 (Opt. 5 lbs.)				4379 (Std.) 1527 (Opt. 2.5 lbs.) & 3061 (Opt. 5 lbs.)					
31	6	Screw	7531				7531					
32	1	Pressure Gauge	7704				7704					
33	1	Diaphragm Nut	2912				2912SS6					
34	1	O-Ring	265				265					
35	10	Screw	236				236					
36	1	Nipple	648				648SS6					
37	1	Diaphragm *	110				110					
38	1	Tee	219				219SS6					
39	1	Lower Pilot Housing	1356				1356 ‡					
40	1	Elbow / Connector	877	876	877	877	877SS6	876SS6	877SS6	877SS6		
41	1	Pilot Seat *	113				113SS6					
42	1	Pilot Seat *	565				565SS6					
43	1	Pilot Plug *	112				112					
44	1	Spring *	1360				1360HAC					
45	1	Tubing	2559SS6	74SS			2559SS6	74SS6				
46	1	Spring	1388	1528	1529	1575	1388	1528	1529	1575		
47	1	Lower Housing	1704	1632	145	146	1704 ‡	1632 ‡	145 ‡	146 ‡		
48	1	O-Ring *	154	155	156	157	154	155	156	157		
49		Elbow	877				877SS6					
50	1	Seat Disc	159	160	161	162	2493SS6	2494SS6	2495SS6	2961SS6		
51	1	Standard Ratio Plug	177SS6	178	179	180	177SS6	3076SS6	3078SS6	3079SS6		
		Reduced Ratio Plug	4933	1228SS6	177SS6	178	4933SS6	1228SS6	177SS6	3076SS6		
52	1	Removable Seat	272K	273K	274K	275K	2496SS6K	2497SS6K	2498SS6K	3075SS6K		
53	1	Nut *	173	906	175	175	173SS6	174SS6	175SS6	175SS6		
Repair Kits			RUID	RUJD	RUKD	RTYD	RUID	RUJD	RUKD	RTYD		
			* These parts are recommended spare parts and are stocked as repair kits.									

PRESSURE REGULATORS

1 INCH GAS OUNCES BACK PRESSURE TO ATMOSPHERE W/OUTSIDE SUPPLY
MODEL AB PARTS DRAWING

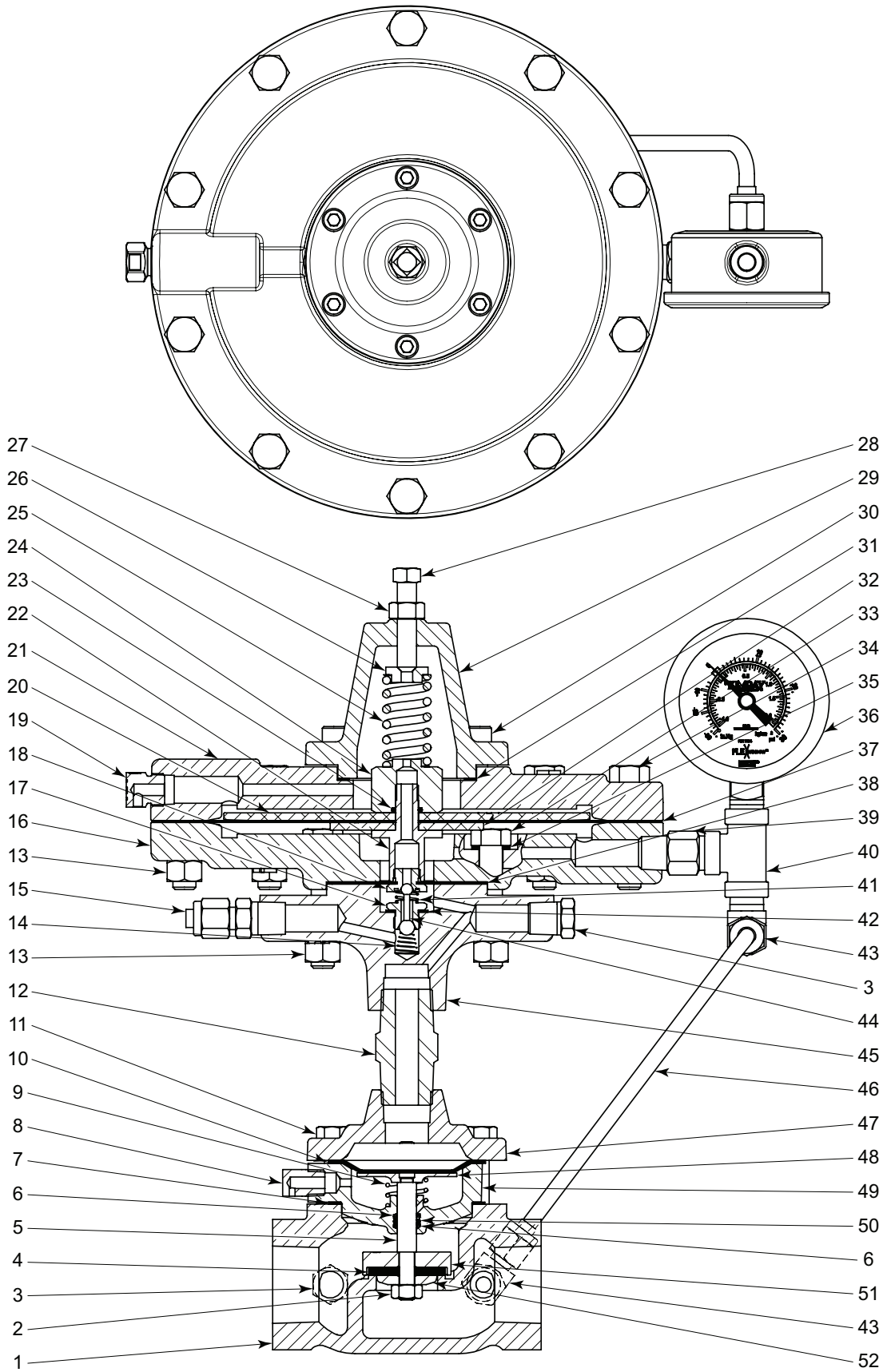

All Pictures shown are for illustration purpose only. Actual product may vary due to product enhancement.



PRESSURE REGULATORS

1 INCH GAS OUNCES BACK PRESSURE TO ATMOSPHERE W/OUTSIDE SUPPLY
MODEL AB PARTS LIST

ITEM	QTY.	DESCRIPTION	PART NUMBER	
			STANDARD	CORROSIVE
1	1	Body	2033	2033 ‡
2	1	Nut *	172	172SS6
3	2	Plug	699	699SS6
4	1	Seat *	163	163HSN
5	1	Valve Stem	137X	138SS6X
6	2	Back Up *	148T	148T
7	1	Gasket *	195	195
8	1	Vent Plug	1357	1357SS6
9	1	Spring	1358	1358
10	1	Diaphragm *	127	127
11	6	Bolt	2007	2007
12	1	Nipple	2516	2516SS6
13	14	Nut	241	241
14	1	Spring *	1360	1360HAC
15	1	Connector	874	874SS6
16	1	Lower Pilot Housing	1356	1356 ‡
17	1	Pilot Seat *	565	565SS6
18	1	Pilot Seat *	113	113SS6
19	1	Vent Plug	147	147SS6
20	1	Upper Diaphragm Plate	1208	1208SS6
21	1	Upper Pilot Housing	1206	1206 ‡
22	1	Stem	2913	2913SS6
23	1	O-Ring *	265	265
24	1	Diaphragm Nut	2912	2912SS6
25	1	Spring	4379 (Std.) 1527 (Opt. 2.5 lbs.) & 3061 (Opt. 5 lbs.)	4379 (Std.) 1527 (Opt. 2.5 lbs.) & 3061 (Opt. 5 lbs.)
26	1	Spring Guide	7148S6 (Std.) 636SS6 (Opt. 2.5 & 5 lbs.)	7148S6 (Std.) 636SS6 (Opt. 2.5 & 5 lbs.)
27	1	Nut	922	922
28	1	Adjusting Screw	897	897
29	1	Bonnet	1336	1336 ‡
30	6	Screw	7531	7531
31	1	Gasket *	1216	1216
32	1	Lower Diaphragm Plate	1340	1340SS6
33	4	Screw	191	191
34	10	Screw	236	236
35	4	Gasket *	242	242
36	1	Pressure Gauge	7704	7704
37	1	Diaphragm *	1212	1212
38	1	Diaphragm *	110	110
39	1	Nipple	648	648SS6
40	1	Tee	219	219SS6
41	1	Spring *	566	566HAC
42	1	Gasket *	118	118
43	2	Elbow	875	875SS6
44	1	Pilot Plug *	112	112
45	1	Base	4995	4995 ‡
46	1	Tubing	1383SS6	1383SS6
47	1	Bonnet	4477	4477 ‡
48	1	Diaphragm Plate	132SS6	132SS6
49	1	Lower Housing	142	142 ‡
50	1	O-Ring *	153	153
51	1	Seat Disc	158	158SS6
52	1	Ratio Plug	176SS6	176SS6
‡ Coated Parts available with "K" service type				
Repair Kits			RUAD	RUAD
* These parts are recommended spare parts and are stocked as repair kits.				

PRESSURE REGULATORS

STEEL GAS OUNCES BACK PRESSURE TO ATMOSPHERE W/OUTSIDE SUPPLY
MODEL AB PARTS DRAWING

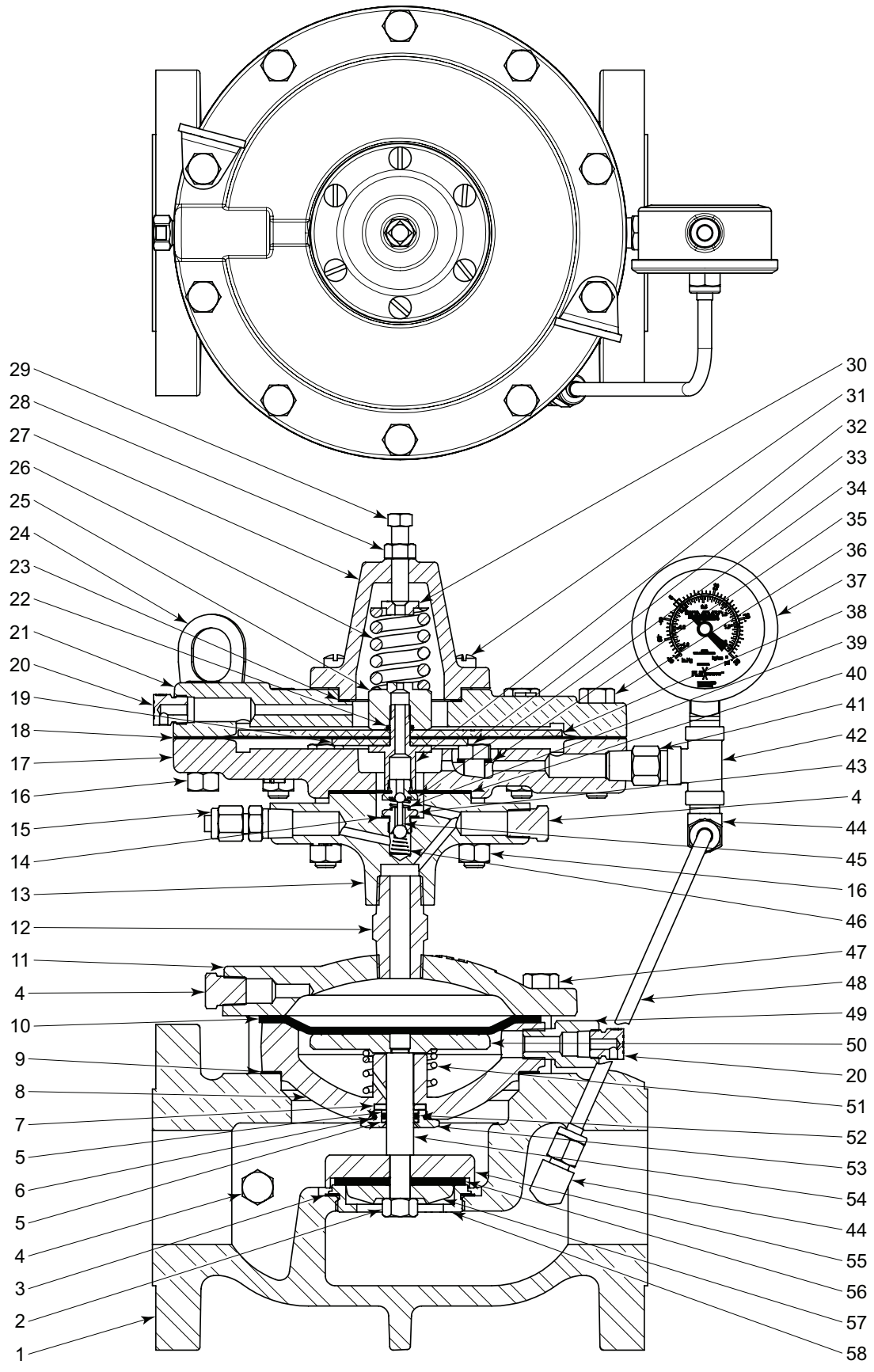

All Pictures shown are for illustration purpose only. Actual product may vary due to product enhancement.



PRESSURE REGULATORS

STEEL GAS OUNCES BACK PRESSURE TO ATMOSPHERE W/OUTSIDE SUPPLY
MODEL AB PARTS LIST

ITEM	QTY.	DESCRIPTION	PART NUMBER							
			STANDARD				CORROSIVE			
			2 INCH	3 INCH	4 INCH	6 INCH	2 INCH	3 INCH	4 INCH	6 INCH
1	1	Body	2468	2469	2470	2959	2468 ‡	2469 ‡	2470 ‡	2959 ‡
2	1	Nut *	173	906		175	173SS6	174SS6		175SS6
3	1	Gasket *	276	277	196	279	276	277	196	279
4	2	Plug	699				699SS6			
5	2	Back Up *	149T	150T	151T	152T	149T	150T	151T	152T
6	1	O-Ring *	5225	5226	5227	4086	5225	5226	5227	4086
7	1	Spacer	4557DS6	4561DS6	4566DS6	4571DS6	4557DS6	4561DS6	4566DS6	4571DS6
8	1	Lower Housing	2481	2482	2483	2957	2481 ‡	2482 ‡	2483 ‡	2957 ‡
9	1	Gasket *	196	197	198	199	196	197	198	199
10	1	Diaphragm *	1706	1640	2015	2140	1706	1640	2015	2140
11	1	Bonnet	2487	2488	2489	2956	2487 ‡	2488 ‡	2489 ‡	2956 ‡
12	1	Nipple	2516				2516SS6			
13	1	Base	4995				4995 ‡			
14	1	Gasket *	118				118			
15	1	Connector / Elbow	874	876	875		874SS6	876SS6	875SS6	
16	14	Nut	241				241			
17	1	Lower Pilot Housing	1356				1356 ‡			
18	1	Diaphragm *	1212				1212			
19	1	Lower Diaphragm Plate	1340				1340SS6			
20	2	Vent Plug	147				147SS6			
21	1	Upper Pilot Housing	1206				1206 ‡			
22	1	O-Ring *	265				265			
23	1	Gasket *	1216				1216			
24	2	Lifting Ring	7559			----	7559			----
25	1	Diaphragm Nut	2912				2912SS6			
26	1	Spring	4379 (Std.) 1527 (Opt. 2.5 lbs.) & 3061 (Opt. 5 lbs.)				4379 (Std.) 1527 (Opt. 2.5 lbs.) & 3061 (Opt. 5 lbs.)			
27	1	Bonnet	1336				1336 ‡			
28	1	Nut	922				922			
29	1	Adjusting Screw	897				897			
30	1	Spring Guide	7148S6 (Std.) 636SS6 (Opt. 2.5 & 5 lbs.)				7148S6 (Std.) 636SS6 (Opt. 2.5 & 5 lbs.)			
31	6	Screw	7531				7531			
32	1	Stem	2913				2913SS6			
33	4	Screw	191				191			
34	1	Pilot Seat *	113				113SS6			
35	4	Gasket *	242				242			
36	10	Screw	236				236			
37	1	Pressure Gauge	7704				7704			
38	1	Upper Diaphragm Plate	1208				1208SS6			
39	1	Spring *	566				566HAC			
40	1	Diaphragm *	110				110			
41	1	Nipple	648				648SS6			
42	1	Tee	219				219SS6			
43	1	Pilot Seat *	565				565SS6			
44	2	Elbow	875		874		875SS6		874SS6	
45	1	Pilot Plug *	112				112			
46	1	Spring	1360				1360HAC			
47	(QTY)	Bolt	965 (8)	907(10)	907 (12)	2142 (16)	965 (8)	907(10)	907 (12)	2142 (16)
48	1	Tubing	2552SS6		126SS6	2505SS6	2552SS6		126SS6	2505SS6
49	1	Adapter	7244				7244S6			
50	1	Diaphragm Plate	2490	2491	2492	2958	2490S6	2491S6	2492S6	2958SS6
51	1	Spring	1388	7132	1529	1575	1388	7132	1529	1575
52	1	O-Ring *	154	807	156	157	154	807	156	157
53	1	Retainer	4557ES6	4561ES6	4566ES6	4571ES6	4557ES6	4561ES6	4566ES6	4571ES6
54	1	Valve Stem	138	139	140	141	138SS6	139SS6	140SS6	141SS6
55	1	Seat Disc	2493SS6	2494SS6	2495SS6	2961SS6	2493SS6	2494SS6	2495SS6	2961SS6
56	1	Seat *	164HSN	165HSN	166HSN	167HSN	164HSN	165HSN	166HSN	167HSN
57	1	Standard Ratio Plug	177SS6	178	179	3079SS6	177SS6	3076SS6	3078SS6	3079SS6
		Reduced Ratio Plug	4933	1228SS6	177SS6	178	4933SS6	1228SS6	177SS6	3076SS6
58	1	Removable Seat	2496SS6K	2497SS6K	2498SS6K	3075SS6K	2496SS6K	2497SS6K	2498SS6K	3075SS6K
Repair Kits			RTN	RTO	RTP		RTNHSN	RTOHSN	RTPHSN	
* These parts are recommended spare parts and are stocked as repair kits.										

Table 1 - Flow Coefficient(Cv) at % stem travel for Pilot-operated Regulators											
1" Pressure Regulator											
Trim Size in.(mm)	Cf	Valve Opening Percentage									
		10	20	30	40	50	60	70	80	90	100
1/2 in (12mm) Reduced	0.75	0.4	0.7	0.9	1.3	1.8	2.5	3.2	3.9	4.5	5
1 in (25mm) Full Port	0.74	1.1	1.8	2.4	3.4	4.8	6.6	8.5	10.2	11.9	13.2
2" Pressure Regulator											
Trim Size in. (mm)	Cf	Valve Opening Percentage									
		10	20	30	40	50	60	70	80	90	100
1 1/4 in (31 mm) Reduced	0.75	1.8	2.8	3.9	5.4	7.7	10.5	13.6	16.2	19.0	21.0
2 in Removable Full Port *	0.84	4.0	6.2	8.6	12.1	17.2	23.5	30.4	36.3	42.5	47.0
2 in (50 mm) Full Port *	0.75	4.4	6.9	9.5	13.4	19.1	26.0	33.6	40.2	47.0	52.0
3" Pressure Regulator											
Trim Size in. (mm)	Cf	Valve Opening Percentage									
		10	20	30	40	50	60	70	80	90	100
1 5/8 in (66 mm) Reduced	0.82	2.9	4.5	6.2	8.8	12.5	17.0	22.0	26.3	30.7	34.0
3 in (76 mm) Full Port	0.75	9.9	15.6	21.5	30.2	42.9	58.6	75.7	90.4	105.7	117.0
4" Pressure Regulator											
Trim Size in. (mm)	Cf	Valve Opening Percentage									
		10	20	30	40	50	60	70	80	90	100
2 in (50 mm) Reduced	0.80	4.7	7.3	10.1	14.2	20.2	27.5	35.6	42.5	49.7	55.0
4 in (100 mm) Full Port	0.75	17.8	27.9	38.6	54.2	77.0	105.2	135.9	162.2	189.8	210.0
6" Pressure Regulator											
Trim Size in. (mm)	Cf	Valve Opening Percentage									
		10	20	30	40	50	60	70	80	90	100
3 in (76 mm) Reduced	0.80	10.2	16.0	22.0	30.9	44.0	60.1	77.7	92.7	108.4	120.0
6 in (152 mm) Full Port	0.75	40.6	63.8	88.1	123.8	176.0	240.4	310.6	370.7	433.7	480.0

Kimray flow equations conform to ANSI/ISA - 75.01.01-2002
 Kimray inherent flow characteristics conform to ANSI/ISA 75.11.01 -1985

PRESSURE REGULATORS



DIMENSIONS

BACK PRESSURE
UPSTREAM DIFFERENTIAL PRESSURE
PRESSURE REDUCING-BALANCED
PRESSURE REDUCING VACUUM

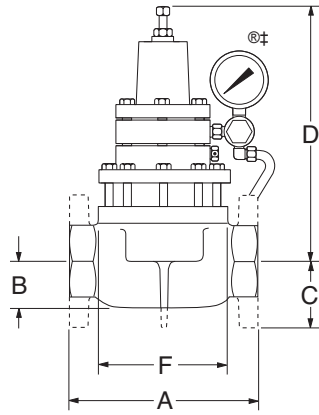

DUCTILE

PRESSURE DIFFERENTIAL
PRESSURE REDUCING
BACK PRESSURE VACUUM
LIQUID BACK PRESSURE

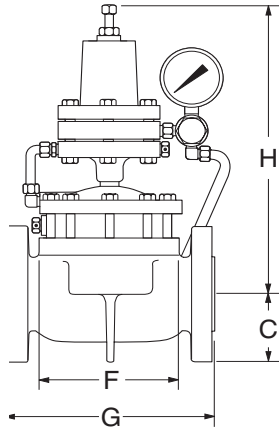

STEEL

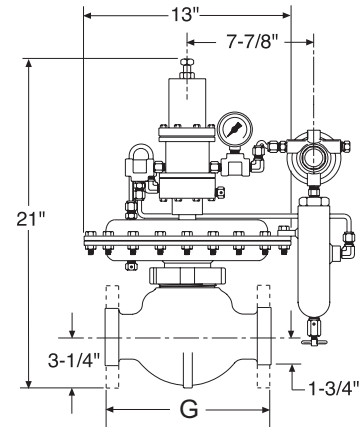

250 S/FGT-BP-S

LOW PRESSURE BACK PRESSURE
OUNCES BACK PRESSURE TO VACUUM
OUNCES PRESSURE REDUCING
OUNCES PRESSURE REDUCING VACUUM
VACUUM BACK PRESSURE TO VACUUM

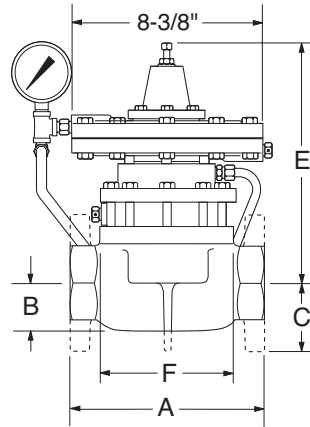

DUCTILE

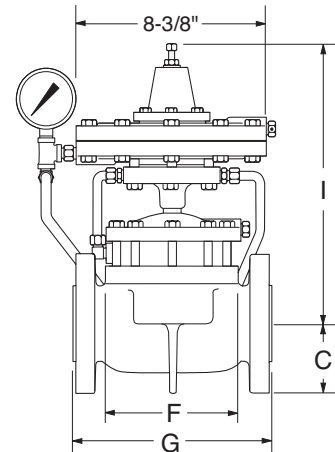

STEEL

LINE SIZE	BODY SIZE	A	B	C	D*	E	F	G	H*	I
1"	NPT	4 3/8"	1 1/8"		7 1/2"	11 5/8"	3 1/4"			
	FLANGED	7 1/4"	1 1/8"	2 1/8"	7 1/2"	11 5/8"	3 1/4"			
2"	NPT	8 1/2"	2 1/8"		11 1/2"	10 1/2"	6 1/2"			
	FLANGED	9"		3"	11 1/2"	10 1/2"	6 1/2"	9 1/8"	14 1/2"	14"
	GROOVED	8 3/4"	2 1/8"		11 1/2"	10 1/2"	6 1/2"			
250 S/FGT	NPT							10 1/2"		
	FLANGED							10 3/8"		
3"	NPT	12 1/16"	3 1/16"		13"	12"	8 1/2"			
	FLANGED	12 3/16"		3 3/4"	13"	12"	8 1/2"	12 3/8"	16 1/2"	15 1/2"
4"	NPT	15" 1/16"	4"		14 1/2"	13 3/16"	10 1/2"			
	FLANGED	15 1/16"		4 1/2"	14 1/2"	13 3/16"	10 1/2"	15 1/16"	18 1/2"	16 11/16"
6"	FLANGED	22"		5 1/2"	17"	17 7/8"	16"	21 15/16"	20 1/2"	18 3/8"

FLANGE DIMENSIONS ARE ANSI 125/150 STANDARD. *Add 7/8" to Pressure Reducing Balanced and Up Stream Differential Pressure Regulators for this dimension.

All Pictures shown are for illustration purpose only. Actual product may vary due to product enhancement.
‡ Configuration of Back Pressure Control Valve is a trademark of Kimray, Inc.

www.kimray.com

Table 2 - Seal Options		
Part	Standard Material	Optional Material
Seat	HSN	FKM, AFLAS®
O-rings	Nitrile	HSN, FKM, AFLAS®
All Diaphragms	Nitrile	HSN, FKM, AFLAS®

Table 3 - Seal Specifications				
	NITRILE	HIGHLY SATURATED NITRILE	FKM	AFLAS®
Kimray Suffix	-	HSN	V	AF
Resistance	Abrasion	G	G-E	G
	Acid	F	G-E	E
	Chemical	F	F	E
	Cold	G	G	P
	Flame	P	P	E
	Heat	G	E	E
	Oil	G-E	E	E
	Ozone	P	G	G-E
	Set	G	G	G-E
	Tear	F	F	F
	Water/Steam	F	E	P
	Weather	F	G	E
	CO2	F-G	G	G
	H2S	P	F	P
	Methanol	F	E	P
Properties	Dynamic	G	G	G
	Electrical	F	F	G-E
	Impermeability	G	G	G
	Tensile Strength	G	G-E	G
Temp. Range	-20° to +225°F	-20° to +250°F	-15° to +400°F	+15° to +450°F
	-29° to +107°C	-29° to +121°C	-26° to +204°C	-9° to +232°C
RATINGS: P-POOR, F-FAIR, G-GOOD, E-EXCELLENT				

Table 4 - Material Options

Part Description	Valve Size	Standard Material	Corrosive Material
Ratio Plug	1" & 2"	316 Powdered Metal SS-316NI-25	
	1" & 2" Reduced Trim	Alloy Steel (ASTM A108)	316SS (ASTM A479)
	3"	Powdered Metal F-008	316SS (ASTM A479)
	4" & 6"	Ductile (ASTM A395)	316SS (ASTM A479)
Seat Disc	1"	Powdered Metal F-008	316SS (ASTM A479)
	2", 3" & 4"	Ductile (ASTM A395)	316SS (ASTM A351 CF8M)
	6"	Ductile (ASTM A395)	316SS (ASTM A 240)
Stem	1" thru 6"	303SS (ASTM A582)	316SS (ASTM A479)
Body	1" thru 6"	Ductile (ASTM A395)	WCB (ASTM A216) + Kimcoat
	2" thru 6"	WCB (ASTM A216)	316SS (ASTM A351 CF8M)
Tubing	1" thru 6"	304SS (ASTM A249)	316SS (ASTM A213)
Removable Seat	2" thru 6" Ductile Body	Ductile (ASTM A395)	316SS (ASTM A351 CF8M)
	2" thru 6" Steel Body	316SS (ASTM A351 CF8M)	

Series:
R = Pressure Regulator

Model: _____

Line Size:
1 = 1 NPS (VR & AB only)
2 = 2 NPS
3 = 3 NPS
4 = 4 NPS
6 = 6 NPS

End Connection:
SA = FNPT
AR = 150RF Flange (not available in 1 NPS)
GV = Grooved (2 NPS only)

Shell Material:
D = Ductile Iron
W = Steel (WCB) (VB, AB & LR only)

Inner Valve Size:
F = Full Port
R = Reduced Port

Control Range:
2 = 0-20 psig Spring
3 = 0-5 psig Spring
4 = 0-2.5 psig Spring

Service Type:
S = Standard
C = Corrosive
K = Corrosive with Coated Shell Components

R	BP	2	SA	D	F	2	S	
---	----	---	----	---	---	---	---	--

Options: Additional cost and lead times will apply
If multiple options required input in sequential order
Leave blank if no options required

1 = NACE Certification (Corrosive Option Only)
2 = Hydrostatic Test Certification
3 = MTR (Shell Components)
A = AFLAS Elastomers
H = HSN Elastomers
V = FKM Elastomers
X = Export (Hydrostatic test, MTR & 3.1)

Not all selections available on all products listed.
See the following product pages for available options
06:10.9 - 06:10.11, 06:30.5 - 06:30.9,
06:50.9 - 06:50.13, 06:90.1 - 06:90.13