

APPLICATIONS:

Used on oil and gas separators, freewater knockouts (FWKO), horizontal emulsion treaters and similar equipment where a float is desired to monitor fluid level.

FEATURES:

- Teflon packed rotary stuffing box
- Removable, bonnet type trunnion assembly
- 3/4" float arm hub
- ANSI 150 Flange
- 8" pipe x 5" long weldneck
- 8" ACME thread hammer union
- ASME code acceptable

CERTIFICATIONS:

Canadian Registration Number (CRN):
0H13107.2134567890NTY
Kimray is an ISO 9001- certified manufacturer.

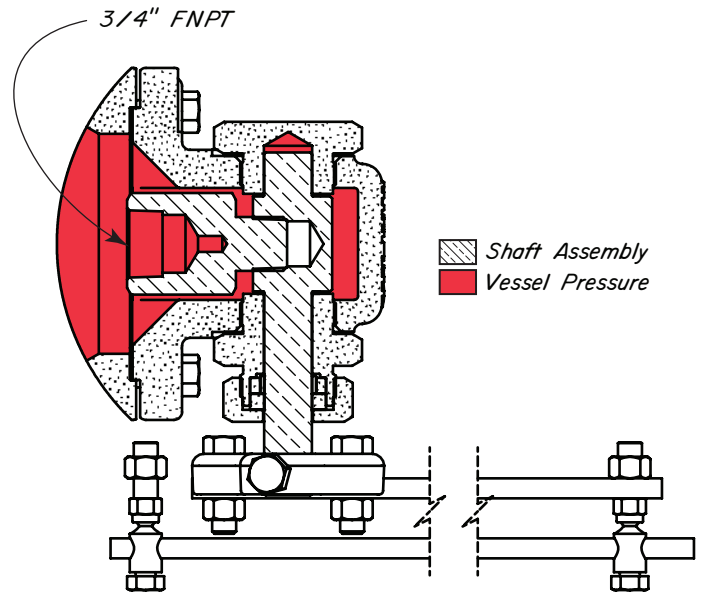

Standard Order Code	Description	Line Size	Connection Type	Max. W.P. psig ††
CCA	612 TO-D	6"	150 RF	250
CCB	812 TO-D	8"		
CCC	1012 TO-D	10"		
CCT	850 HUTA	8"	Weld-neck	500
CCF	25 TOB-D	---	Bolt on	
CCG	50 TOB-S	---	Weld-up	

NOTES:

For standard & optional seals, metals, Cf Cv values, material specifications & dimensions see technical data on pages 03:1 - 03:VI
†† Max W.P. values based on -20°F to 100°F.

LIQUID DUMP VALVES LEVER OPERATED



TRUNNION ASSEMBLY
MODEL 612, 812, 1012 TO-D

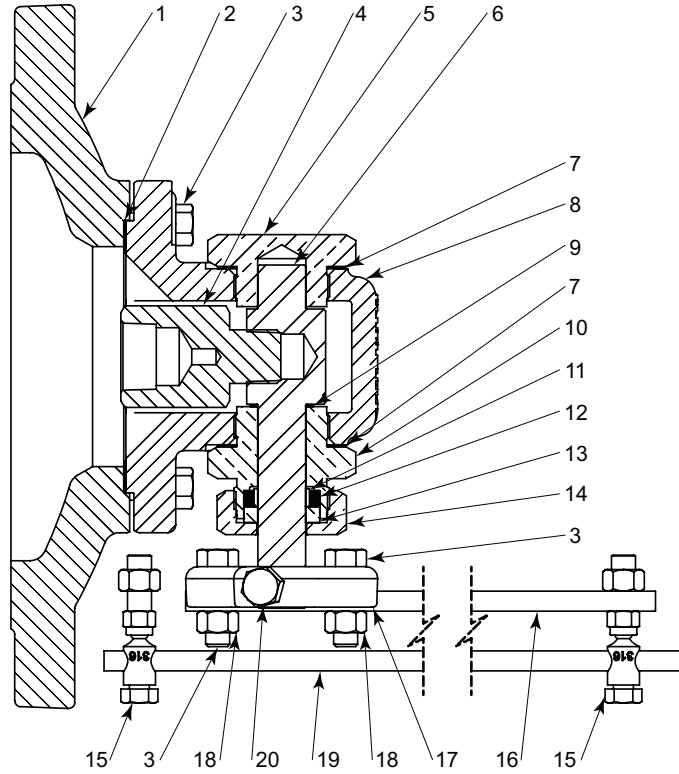

ITEM	QTY.	DESCRIPTION	PART NO.		
			6 inch	8 inch	10 inch
1	1	Cover	432	433	434
2	1	Gasket	437		
3	8	Bolt	247		
4	1	Float Arm Hub	7599		
5	1	Trunnion Plug	369		
6	1	Shaft	7606		
7	2	Gasket *	366		
8	1	Bonnet	7014		
9	1	Thrust Washer *	362		
10	1	Stuffing Box	359		
11	1	Packing *	356		
12	1	Pacing Ring *	353		
13	1	Packing Follower *	350		
14	1	Stuffing Box Nut	347		
15	2	Ball Joint	753		
16	1	Lever	340		
17	1	Lever Hub	7602		
18	2	Nut	241		
19	1	Linkage Rod	754		
20	1	Set Screw	7608		
Repair Kits			REE		

* These parts are stocked as repair kits.

OPTIONAL WEIGHTED LEVER BARS & WEIGHTS			
ITEM	QTY.	DESCRIPTION	PART NO.
16	1	7 lb. Weight (not shown)	424
		9 lb. Weight (not shown)	425
		11 lb. Weight (not shown)	426
16	1	24" Long Lever Bar	7591L24
		36" Long Lever Bar	7591L36
Ordered separately from item code			

OPTIONAL LONGER LEVER BARS			
ITEM	QTY.	DESCRIPTION	PART NO.
16	1	16" Long Lever Bar	340L16
		20" Long Lever Bar	340L20
		24" Long Lever Bar	340L24
		30" Long Lever Bar	340L30
16	1	36" Long Lever Bar	340L36
Ordered separately from item code			

All Pictures shown are for illustration purpose only. Actual product may vary due to product enhancement.

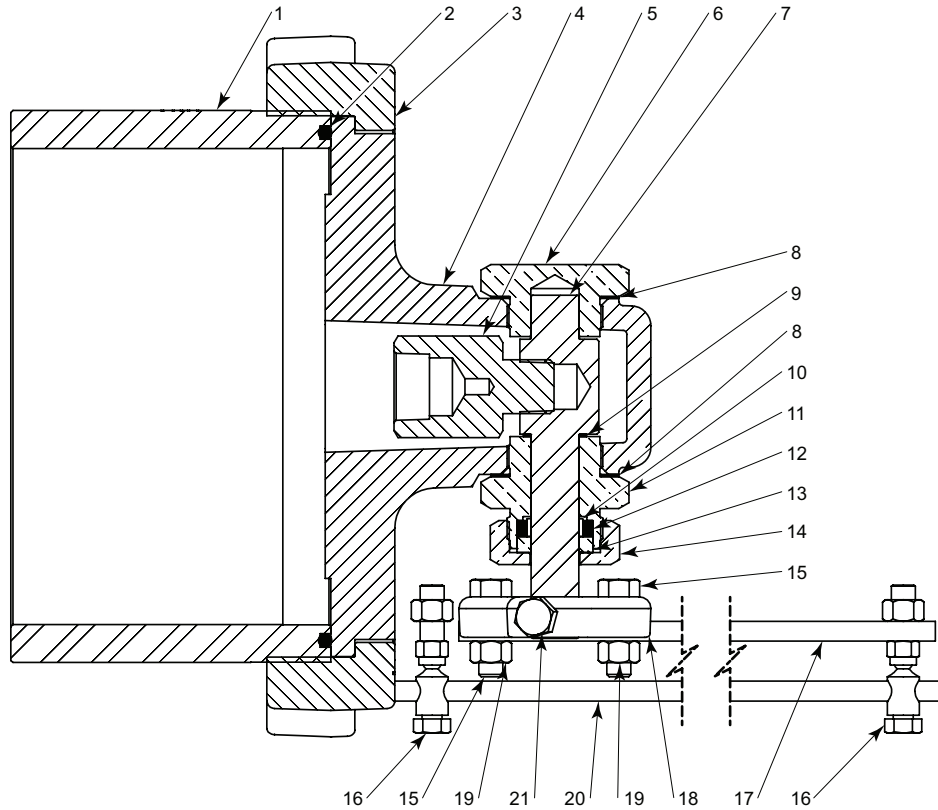

ITEM	QTY.	DESCRIPTION	PART NO.
1	1	5" Long Weld Neck	2757L5
		8" Long Weld Neck	2757L8
		15" Long Weld Neck	2757L15
2	1	O-Ring *	2758
3	1	Hammer Union Nut	2756
4	1	Bonnet	4085
5	1	Float Arm Hub	7599
6	1	Trunnion Plug	369
7	1	Shaft	7606
8	2	Gasket *	366
9	1	Thrust Washer *	362
10	1	Packing *	356
11	1	Stuffing Box	359
12	1	Packing Ring *	353
13	1	Packing Follower *	350
14	1	Stuffing Box Nut	347
15	2	Bolt	247
16	2	Ball Joint	753
17	1	Lever	340
18	1	Lever Hub	7602
19	2	Nut	241
20	1	Linkage Rod	754
21	1	Set Screw	7608
Repair Kits			REE

* These parts are stocked as repair kits.

OPTIONAL WEIGHTED LEVER BARS & WEIGHTS			
ITEM	QTY.	DESCRIPTION	PART NO.
17	1	7 lb. Weight (not shown)	424
		9 lb. Weight (not shown)	425
		11 lb. Weight (not shown)	426
17	1	24" Long Lever Bar	7591L24
		36" Long Lever Bar	7591L36
Ordered separately from item code			

OPTIONAL LONGER LEVER BARS			
ITEM	QTY.	DESCRIPTION	PART NO.
17	1	16" Long Lever Bar	340L16
		20" Long Lever Bar	340L20
		24" Long Lever Bar	340L24
17	1	30" Long Lever Bar	340L30
		36" Long Lever Bar	340L36
Ordered separately from item code			

All Pictures shown are for illustration purpose only. Actual product may vary due to product enhancement.

LIQUID DUMP VALVES LEVER OPERATED



TRUNNION ASSEMBLY MODEL 25 TOB

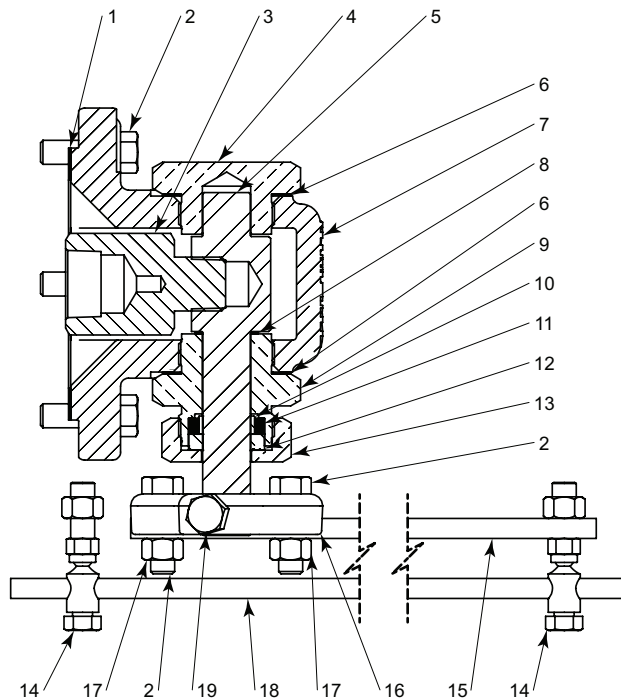

ITEM	QTY.	DESCRIPTION	PART NO.	
			STANDARD	316 SS6
1	1	Gasket		437
2	8	Bolt		247
3	1	Float Arm Hub	7599	7599S6
4	1	Trunnion Plug	369	369S6
5	1	Shaft	7606	7606S6
6	2	Gasket *		366
7	1	Bonnet		436
8	1	Thrust Washer *		362
9	1	Stuffing Box	359	359SS6
10	1	Packing *		356
11	1	Packing Ring *		353
12	1	Packing Follower *	350	350SS6
13	1	Stuffing Box Nut	347	347SS6
14	2	Ball Joint		753
15	1	Lever		340
16	1	Lever Hub		7602
17	2	Nut		241
18	1	Linkage Rod		754
19	1	Set Screw		7608
Repair Kits				REE

* These parts are stocked as repair kits.

OPTIONAL WEIGHTED LEVER BARS & WEIGHTS			
ITEM	QTY.	DESCRIPTION	PART NO.
15	1	7 lb. Weight (not shown)	424
		9 lb. Weight (not shown)	425
		11 lb. Weight (not shown)	426
	1	24" Long Lever Bar	7591L24
		36" Long Lever Bar	7591L36
Ordered separately from item code			

OPTIONAL LONGER LEVER BARS			
ITEM	QTY.	DESCRIPTION	PART NO.
15	1	16" Long Lever Bar	340L16
		20" Long Lever Bar	340L20
		24" Long Lever Bar	340L24
	1	30" Long Lever Bar	340L30
		36" Long Lever Bar	340L36
Ordered separately from item code			

OPTIONAL ADAPTER PLATE	
DESCRIPTION	PART NO.
6" O.D. x 1" Thick plate for welding applications	705
Ordered separately from item code	

All Pictures shown are for illustration purpose only. Actual product may vary due to product enhancement.

Table 1 - Flow Coefficient(Cv) for Lever Operated Dump Valves													
Line Size	Trim Size in. (mm)	Trim Type	Cf	Valve Opening Percentage									
				10	20	30	40	50	60	70	80	90	100
LD - Diaphragm Balanced													
2"	1 1/2 in (38mm)	Linear (Nominal)	0.79	5.0	8.5	11.7	14.6	17.0	19.0	20.5	21.6	22.6	23.3
3"	2 1/4 in (57 mm)		0.79	6.7	11.1	15.6	20.3	24.8	29.2	33.4	37.2	40.7	43.8
4"	3 in (76 mm)		0.79	12.0	18.9	25.8	32.8	39.9	46.9	53.7	60.0	65.7	70.1
6"	4.88 in (124 mm)		0.79	14.2	21.0	31.6	61.2	98.3	139.0	179.7	217.6	250.2	277.0
LP - Piston Balanced Throttling													
2"	1 1/2 in (38mm)	Linear (Nominal)	0.75	3.5	5.0	7.4	9.6	11.8	13.9	16.2	18.4	20.4	22.7
	2 in (51 mm)		0.75	6.6	12.3	18.4	24.2	29.5	34.1	38.0	41.2	44.0	47.0
3"	3 in (76 mm)		0.75	12.7	18.7	29.0	41.0	52.9	63.4	71.9	78.4	83.7	89.0
LB - Piston Balanced													
2"	2 in (51 mm)	Linear (Nominal)	0.79	5.0	8.5	11.7	14.6	17.0	19.0	20.5	21.6	22.6	23.3
3"	3 in (76 mm)		0.79	6.7	11.1	15.6	20.3	24.8	29.2	33.4	37.2	40.7	43.8
4"	4 in (76 mm)		0.79	12.0	18.9	25.8	32.8	39.9	46.9	53.7	60.0	65.7	70.1

Kimray flow equations conform to ANSI/ISA - 75.01.01-2002
 Kimray inherent flow characteristics conform to ANSI/ISA 75.11.01 -1985

LIQUID DUMP VALVES LEVER OPERATED



DIMENSIONS TRUNNION ASSEMBLY

612, 812 & 1012 TO-D

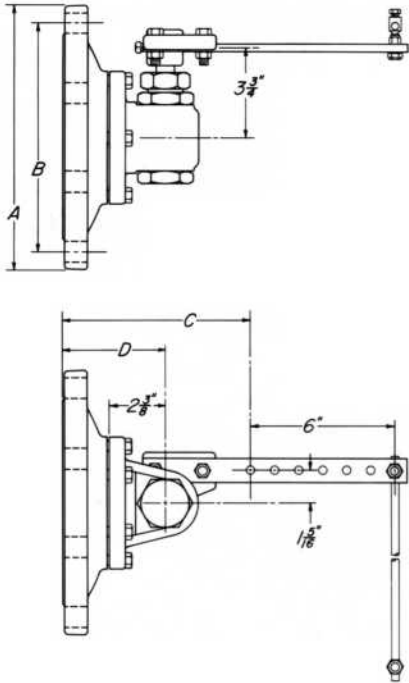

25 TOB

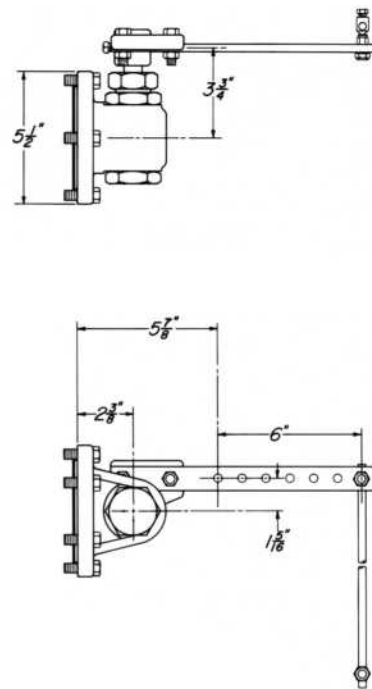

SIZE	NUMBER	A	B	C	D	No. SIZE OF BOLTS
6	612 TO	11 in	9 1/2 in	7 1/4 in	4 1/4 in	8 3/4 x 3 1/2
8	812 TO	13 1/2 in	11 3/4 in	7 1/4 in	4 1/4 in	8 3/4 x 3 1/2
10	6 1/8 in	16 in	14 1/4 in	7 1/2 in	4 1/2 in	12 7/8 x 3 1/2

All dimensions are in inches.

HUTA

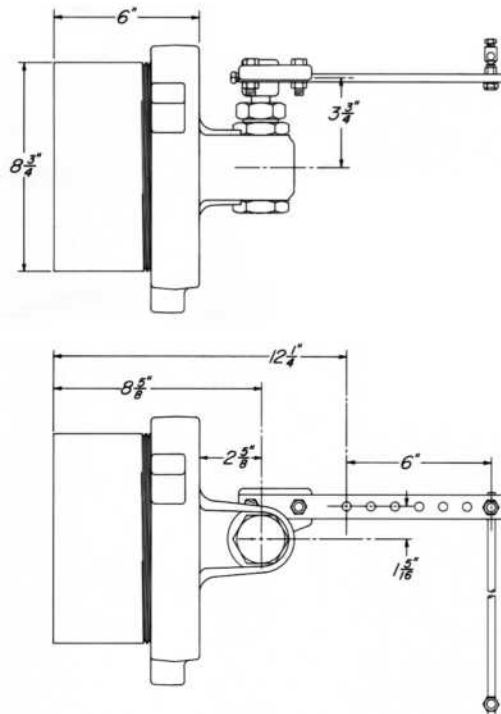

50 TOB-S

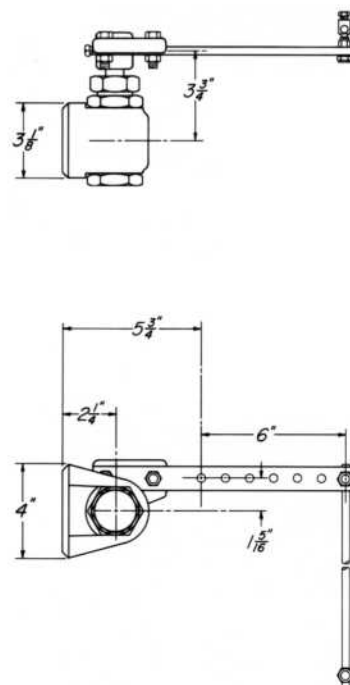

All Pictures shown are for illustration purpose only. Actual product may vary due to product enhancement.

Table 2 - Seal Options Dump Valves		
Part	Standard Material	Optional Material
O-rings	HSN	FKM
Diaphragm	HSN	FKM
Seat	HSN	FKM

Table 3 - Seal Options Trunnion Assemblies		
Part	Standard Material	Optional Material
O-rings	HSN	FKM

Table 4 - Seal Specifications			
		HIGHLY SATURATED NITRILE	FKM
Kimray Suffix		HSN	V
Resistance	Abrasion	G-E	G
	Acid	G-E	G-E
	Chemical	F	E
	Cold	G	P
	Flame	P	E
	Heat	E	E
	Oil	E	E
	Ozone	G	G-E
	Set	G	G-E
	Tear	F	F
	Water/Steam	E	P
	Weather	G	E
	CO2	G	G
	H2S	F	P
Methanol	E	P	
Properties	Dynamic	G	G
	Electrical	F	F
	Impermeability	G	G
	Tensile Strength	G-E	G
Temp. Range		-20° to +300°F	-15° to +400°F
		-29° to +149°C	-26° to +204°C
RATINGS: P-POOR, F-FAIR, G-GOOD, E-EXCELLENT			

Table 5 - Material Options Diaphragm Balanced Dump Valves

Part Description	Standard Material	Corrosive Material
Body	Ductile (ASTM A395)	Ductile (ASTM A395) + Kimcoat
Ratio Plug	2 & 3 inch Delrin (ASTM D4181), 4 & 6 inch Ductile (ASTM A395)	316SS (ASTM A351)
Cage	2 & 3 inch Delrin (ASTM D4181), 4 & 6 inch Ductile (ASTM A395)	316SS (ASTM A351)
Stuffing Box	2 & 3 inch 303SS (ASTM A582), 4 & 6 inch Brass (ASTM B-16)	316SS (ASTM A479)
Bonnet	Ductile (ASTM A395)	Ductile (ASTM A395) + Kimcoat
Seat Disc	4 & 6 inch Ductile (ASTM A395)	4 inch 316SS (ASTM A351)
Stem	2, 3 & 4 inch 303SS (ASTM A582), 6 inch 316SS (ASTM A213)	316SS (ASTM A351)

Table 6 - Material Options Piston Balanced Throttling Dump Valves

Part Description	Standard Material	Corrosive Material
Body	Ductile (ASTM A395)	Ductile (ASTM A395) + Kimcoat
Ratio Plug Full Port	2 inch 316 Powder Metal (ASTM 316-N1-25), 3 inch Powder Metal (F-008)	316 Powder Metal (ASTM 316-N1-25)
Stuffing Box	303SS (ASTM A582)	316SS (ASTM A479)
Bonnet	Ductile (ASTM A395)	Ductile (ASTM A395) + Kimcoat
Stem	303SS (ASTM A582)	316SS (ASTM A484)
Piston	2 inch 316SS (ASTM A484) , 2 inch reduced & 3 inch 303SS (ASTM A582)	316SS (ASTM A484)
Cylinder	303SS (ASTM A582)	316SS (ASTM A484)

Table 7 - Material Options Piston Balanced Dump Valves

Part Description	Standard Material	Corrosive Material
Body	Ductile (ASTM A395)	Ductile (ASTM A395) + Kimcoat
Ratio Plug	2 & 3 inch Delrin (ASTM D4181), 4 inch Ductile (ASTM A395)	316SS (ASTM A351)
Cage	Ductile (ASTM A395)	316SS (ASTM A351)
Stuffing Box	2 & 3 inch 303SS (ASTM A582), 4 inch Brass (ASTM B-16)	316SS (ASTM A479)
Bonnet	Ductile (ASTM A395)	Ductile (ASTM A395) + Kimcoat
Seat Disc	4 inch Ductile (ASTM A395)	4 inch 316SS (ASTM A351)
Stem	303SS (ASTM A582)	316SS (ASTM A479)
Piston	316SS (ASTM A351)	316SS (ASTM A351)
Cylinder	2 & 3 inch 303SS (ASTM A582), 4 inch 316SS (ASTM A351)	316SS (ASTM A249)

Table 8 - Material Options Trunnion Assemblies

Part Description	Standard Material	Corrosive Material
Bonnet	Ductile (ASTM A395)	
Plate	Steel SA515 Grade 70 Plate	
Stuffing Box	Brass B-16 C-36000 HO2	316SS (ASTM A479)
Union Nut	Ductile (ASTM A395)	
Weld Neck	Schedule 100 Pipe ASTM A-106 grade C	

LIQUID DUMP VALVES LEVER OPERATED



CODE BUILDER D SERIES

Series:

D = Dump Valve

Model:

LD = Lever Operated Diaphragm Balanced
 LP = Lever Operated Piston Balanced Throttle (2 & 3 inch only)
 LB = Lever Operated Piston Balanced

Line Size:

2 = 2 NPS
 3 = 3 NPS
 4 = 4 NPS
 6 = 6 NPS

End Connection:

SA = FNPT (2 & 3 NPS only)
 AR = 150RF

Body Type:

A = Angle
 T = Thru

Shell Material:

D = Ductile Iron

Inner Valve Size:

F = Full Port
 R = Reduced Port (LP only)

Actuator:

L = Lever Operated

Service Type:

S = Standard
 C = Corrosive
 K = Corrosive with Coated Shell Components

D LD 2 SA A D F L S

Options: Additional cost and lead times will apply
 If multiple options required input in sequential order
 Leave blank if no options required

1 = NACE Certification (Corrosive Option Only)
 2 = Hydrostatic Test Certification
 3 = MTR (Shell Components)
 H = HSN Elastomers
 V = FKM Elastomers
 X = Export (Hydrostatic test, MTR & 3.1)

Not all selections available on all products listed.
 See product pages 03:10.1 - 03:20.7 for available options