

**KIMRAY**  
INC.®

INSTALLATION  
OPERATION &  
MAINTENANCE  
**GUIDE**



**ELECTRIC PILOT**

All Rights Reserved.

All contents of this publication including illustrations are believed to be reliable. And while efforts have been made to ensure their accuracy, they are not to be construed as warranties for guarantees, express or implied, regarding Kimray products or services described herein or their use or application. All sales are governed by our terms and conditions, which are available on request.

Kimray reserves the right to modify or improve the designs or specifications of such products at any time without prior notice.

# Contents

<b>A</b>	<b>Before you start</b> .....	<b>4</b>
	A1 Scope.....	4
	A2 Introduction.....	4
	A3 Description.....	4
	A4 Maintenance.....	4
	A5 Accessories.....	4
	A6 Electrical Ratings.....	4
	A7 Special Tools and Equipment.....	5
	A8 Specific Conditions of Use.....	6
	A9 Orientation.....	6
<b>1</b>	<b>Installation</b> .....	<b>7</b>
<b>2</b>	<b>Wiring Diagrams</b> .....	<b>8</b>
<b>3</b>	<b>Start-up and Test</b> .....	<b>9</b>
<b>4</b>	<b>Terminal Descriptions</b> .....	<b>9</b>
<b>5</b>	<b>Sensor Selection</b> .....	<b>9</b>
<b>6</b>	<b>Quick Start</b> .....	<b>10-11</b>
<b>7</b>	<b>User Interface</b> .....	<b>12-14</b>
<b>8</b>	<b>Modbus Map</b> .....	<b>15-16</b>
	<b>DISASSEMBLY</b>	
<b>9</b>	<b>Disassembly</b> .....	<b>17</b>
	<b>ASSEMBLY</b>	
<b>10</b>	<b>Assembly</b> .....	<b>17</b>
	<b>TROUBLESHOOTING</b>	
<b>11</b>	<b>Troubleshooting Table</b> .....	<b>17</b>
<b>12</b>	<b>EU Declaration of Compliance</b> .....	<b>18</b>

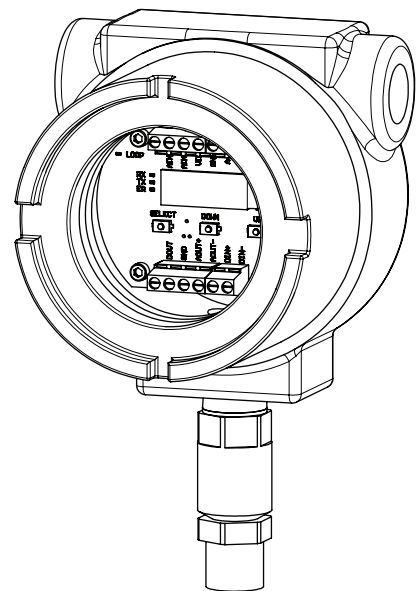

**A Before you start**

**CAUTION:**

Prior to installing, the instructions provided herein should be completely reviewed and understood before operating or repairing this equipment. All CAUTION and WARNING notes must be strictly observed to prevent personal injury or equipment damage.

**A1 Scope**

Do not install, operate, or maintain an electric pilot without being fully trained and qualified with the Kimray installation and maintenance manual. To avoid personal injury or property damage, it is important to carefully read, understand, and follow all the contents of this manual, including all safety cautions and warnings. If you have any questions about these instructions, contact your Kimray applications support group before proceeding.

**A2 Introduction**

This installation manual includes instructions and maintenance information for the Kimray Electric Pilot.

**A3 Description**

Model Number: KEP  
 The Kimray Electric Pilot is designed to provide user selectable control schemes to read an analog 4-20mA sensor and control a 4-20mA valve actuator. This pilot is ideal for applications within the oil and gas production industry where a single sensor is used to control a single valve.

**A4 Maintenance**

**WARNING:**

Explosion Hazard. Do not connect or disconnect this equipment unless power has been removed or the area is known to be nonhazardous.

Maintenance should be performed on a regular basis. An initial inspection interval of 12 months is recommended. Depending on the service conditions of the valve, the inspection interval may be decreased.

**WARNING:**

Always wear protective gloves, clothing, and eyewear when performing any maintenance operations to avoid personal injury. Disconnect any operating lines providing electric power, or a control signal to the pilot.

**CAUTION:**

Keep cover tight while circuits are alive.

**WARNING:**

Use lock-out procedures to be sure that the above measures stay in effect while you work on the equipment.

Related Publications

The following publications are applicable for the actuator. See catalog section Y for product pages.

Abbreviations / Acronyms

The abbreviations that follow are used in this manual.

Term	Definition
PR	Pressure Reducing
BP	Back Pressure
PID	Proportional, Integral, and Derivative method of process control
PV	Process Value – the value that is being measured
SV	Set Value – the desired process value
CO	Controller output – percentage open of the valve

**A5 Accessories**

A 4-20mA sensor is required to detect the process value that will be controlled. Loop power is provided by the KEP. Approximately 2.5VDC of headroom is required for protection and detection circuitry of the analog sensor. For example, if 12V is supplied to the pilot, the sensor must be able to work at 9.5V. The following sensors available from Kimray will work from 8-30VDC.

PRESSURE TRANSDUCER	
Part No.	Pressure Range
KSGS100PG	0-100 PSIG
KSGS300PG	0-300 PSIG
KSGS750PG	0-750 PSIG
KSGS20CPS	0-2000 PSIG
KSGS40CPS	0-4000 PSIG
KSGS60CPS	0-6000 PSIG

**A6 Electrical Ratings**

ELECTRICAL RATINGS			
	Min	Max	Units
Input Voltage (VIN) *	10	30	VDC
Input Current	0.05	0.10	ADC
Ambient Temperature	-40	60	°C
	-40	140	°F
Analog input From Sensor	4-20 mA (powered by VIN)		
Discrete input	Dry Contacts only		
Analog Output to Actuator	4-20 mA (powered by VIN)		
Communications	RS-485 (MODBUS RTU)		
Discrete Output	0 VDC or VIN, up to 1A		

\* SELV / Class2 Power Supply

**A7 Special Tools and Equipment**

No Special Tools Needed

**A8 Specific Conditions of Use**

1. Cable to be rated at least 35°C above maximum ambient rating.
2. All conduit entries are marked in the instruction manual as ½ inch NPT.
3. All entry closure devices shall be ½ inch NPT certified as “Ex db” IIC, “Ex tb” IIIC and “IP66”.
4. Flameproof joints are not permitted to be repaired in the field.
5. Earthing to be connected using minimum 10 AWG or 4.00 mm<sup>2</sup> Cross-Sectional Area via the external earthing crimp connector /or the threaded entry.
6. The Hazardous Location Solutions reducers shall not be used for the direct inter-connection of enclosures.
7. Only one Hazardous Location Solutions reducer shall be used with any single cable entry on the associated equipment.
8. All conduit sealing fittings must be certified as flameproof ‘d’, dust ignition protection ‘tb’, and have a minimum IP66 rating equal to the marking on the enclosure.
9. **“WARNING – POTENTIAL ELECTROSTATIC CHARGING HAZARD – SEE INSTRUCTIONS”**.  
The equipment shall only be cleaned with a damp cloth.
10. **“WARNING - KEEP COVER TIGHT WHILE CIRCUITS ARE ALIVE”**.

**A9 ORIENTATION**

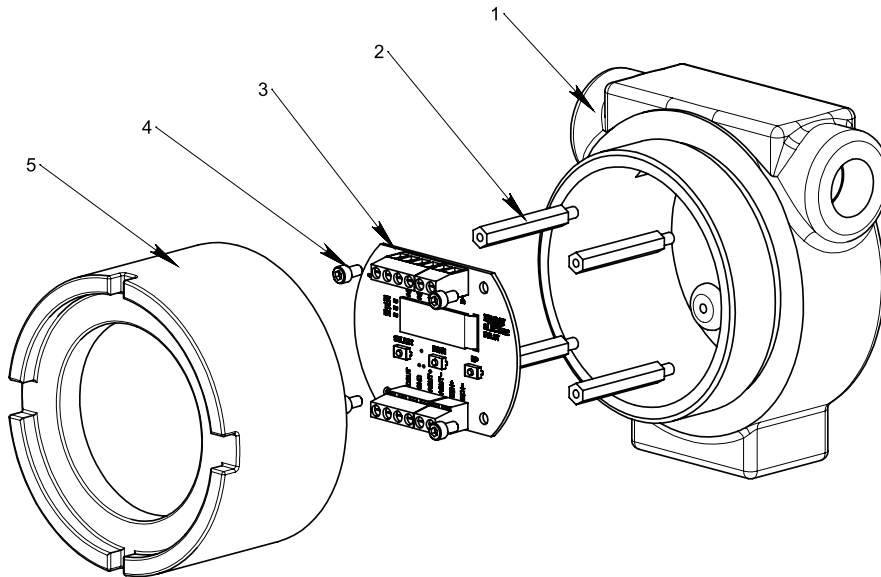

Item	Description	Qty
1	Enclosure Body	1
2	PCB Standoff 6-32 X 3/8" HEX	4
3	Main PCB	1
4	6-32 x 1/4 Socket Head Screw	4
5	Enclosure Cover with Glass	1

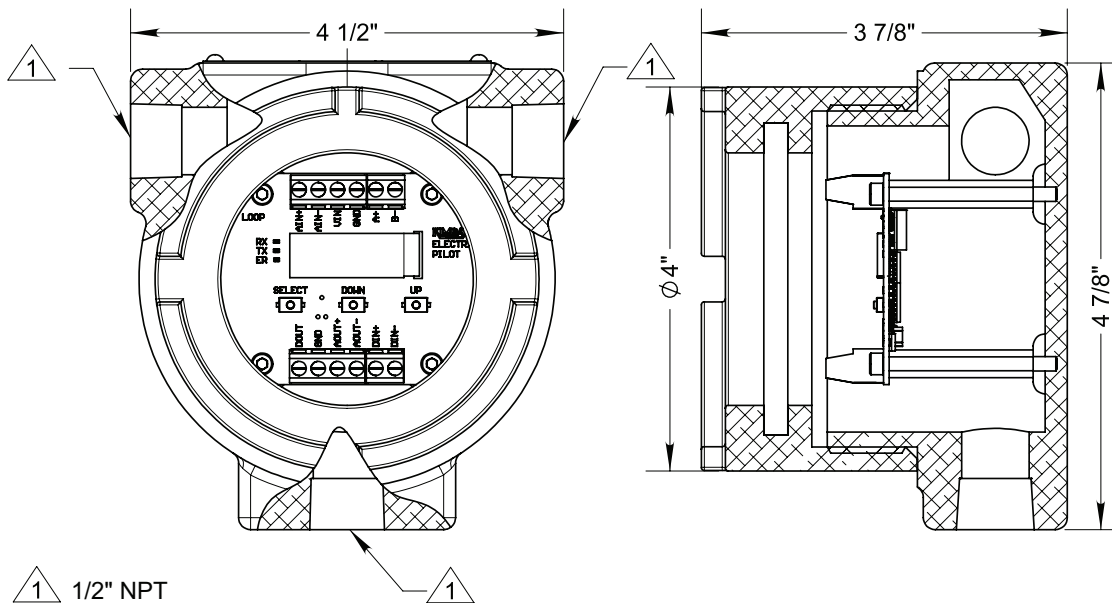

1 1/2" NPT

## 1 Installation

Before installing the Electric Pilot, inspect it for shipment damage and for foreign material that may have collected during shipment.

Verify all pressure connections are tight before pressurizing the system.

Be sure you fully understand the application, operation and connection of the device before installing.

Install the transducer using good piping practices. For threaded (NPT) process connections, use TFE tape or pipe thread sealant on external pipe threads.

If the maximum working pressure of the piping can exceed the proof pressure of the pressure transducer (typically 2 times the full-scale rating), then use an appropriate gauge protector.



### NOTE:

Use good electrical wiring practices and consult with electrician.

### Power Requirements

Ensure a stable DC power source is available for the application. Power supply must be a certified class 2 or SELV ( Separated Extra-Low Voltage) power supply with transient protection. A 100mA (minimum) power supply is required. If the discrete output is used, then the power supply must also be capable of providing the current demanded by the load at the discrete output – up to 1A maximum.

Input voltage can be anywhere in the range from 10 to 30 VDC

### Wiring Instructions

1. Wiring practices must meet the requirements of the NEC and CEC Class I, Division 1 hazardous locations.
2. Conduit seals within 18 inches of the enclosure port are required for explosion-proof installation.
3. Fuse input power to 2A if discrete output is being used. If discrete output is not in use, then the input fuse may be as low as 200mA.
4. Wire size requirements: Use wiring from 12AWG to 20AWG
5. Ensure power is off before connection or removing wires



### NOTE:

If the equipment is used in a manner not specified by the manufacture, the protection provided by the equipment may be impaired.



### WARNING:

To reduce the risk of ignition of hazardous atmospheres, conduit runs must have a seal fitting within 18 inches of the enclosure

### INSTALLATION AND COMMISSION:

- 1) Mount appropriate hardware
- 2) Specify sensor thru menu
- 3) Select control scheme
- 4) Perform auto-tuning or manual-tuning

### ENVIRONMENTAL CONDITIONS:

This equipment is rated for operating in the following environmental conditions:

Pollution degree 2

Installation category II

Altitude 2000m

Humidity 80% to 31°C,

decreasing linearly to 50% RH at 40°C

Max 80% RH, non condensing

Temperature -40°C to 60°C

**2 Wiring Diagrams**

**Basic Hookup**

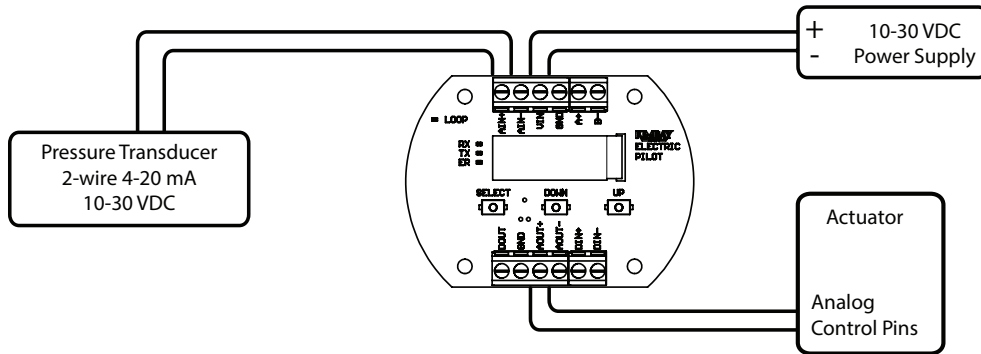

**Discrete Output**

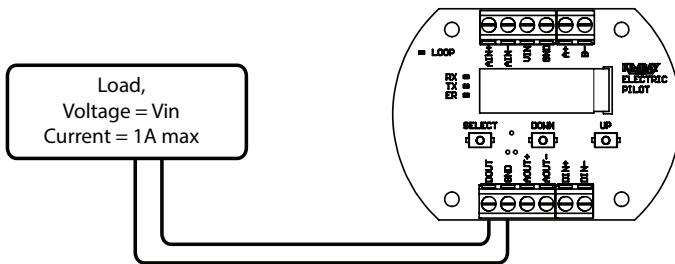

**Discrete Input**

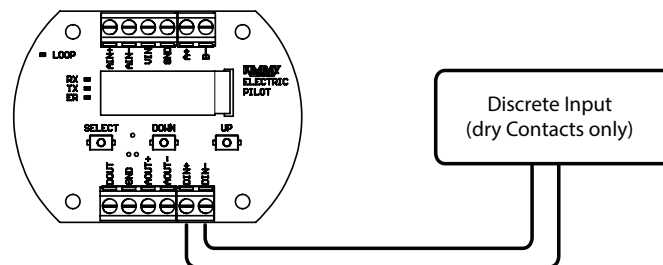

**RS-485 Modbus Connections**

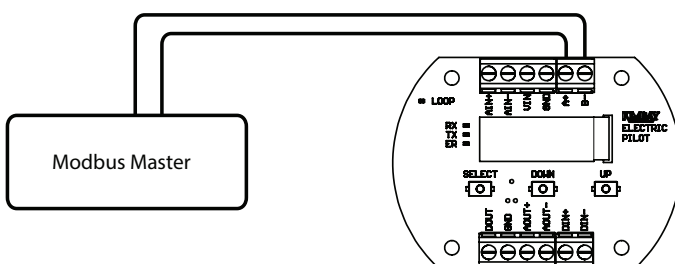



### 3 Start-up and Test

**WARNING:**

Follow strict safety precautions when energizing and de-energizing any system. Permits may be required when commissioning or performing maintenance of electrical devices. Live circuits may generate a spark necessary to ignite flammable or combustible gas and vapors.

Before applying power to the pilot, be aware of the following parameters for your application:

- Sensor Type (Pressure, Flow, Level, or Temperature)
  - Sensor Units (applicable for the type of sensor selected): i.e. PSI for pressure sensor
  - Sensor Range: readings equivalent to 4mA sensor reading and 20mA sensor reading
  - Application Type (PR, BP, GAP, High-Low, Hi-limit, or Low-limit)
1. Apply power to the electric pilot.  
When power is first applied, the screen will splash the Kimray logo. If the screen does not come on, then verify input voltage level and orientation.
  2. Work through the menus to enter the necessary information about the application.
  3. Place the device into MANUAL mode.
  4. Open or close the device as needed.
  5. Place the device into AUTOTUNE if PID control is needed, or RUN mode if GAP or limit control schemes are selected.

### 4. Terminal Descriptions

VIN/GND: Power connections. Can be any DC input voltage in the range of 10-30VDC. This same input voltage will be used to generate loop power for the input loop from the analog sensor as well as the output loop for the analog actuator. Note: The electric pilot features reverse battery protection. If the VIN/GND terminals are hooked up backwards, it will not function until the leads are corrected.

AIN+/AIN-: Connection for input sensor. The sensor can be any 2-wire 4-20mA transducer. Loop voltage is provided by the pilot and will be approximately equal to VIN – 2V due to headroom needed by the functional isolation methods used.

A+/B+: RS485 terminals for MODBUS RTU communication.

AOUT+/AOUT-: Analog output terminals. Provide a powered 4-20mA loop to an analog actuator. Loop power is equal to the input voltage (VIN).

DIN+/DIN-: The discrete input terminals can be hooked up to dry contacts only. Applying the discrete input will disable the pilot. Removing the discrete input will return the pilot to its previous run state. The user can change this through MODBUS or the user interface to a manual reset so that the device does not restart automatically.

DOUT+/GND: Discrete output terminals. These terminals provide sourced output (equal to VIN). Default state is for the output to be ON when a close signal (4mA) is being sent to the actuator. The user can reverse this function through MODBUS or the user interface.

### 5. Sensor Selection (Accessories)

The Electric Pilot is designed to operate with any 4-20mA transducer. Since loop power is provided by the pilot, be mindful of the sensors operating voltage requirements. The Pilot does require approximately 2.5VDC of headroom for the isolation circuitry used. I.E. if the pilot is required to operate over the entire range of 10-30VDC the sensor will need to work from 7.5V to 30 VDC.

**6 QUICK START:**

**PRESSURE REDUCING APPLICATION**

SENSOR TYPE <b>PRESSURE</b>	Use the UP/DOWN Buttons to change the selection	Press SELECT to save
UNITS OF PRESSURE <b>PSI</b>	UP/DOWN to change the units to match your sensor	Press SELECT to save
SENSOR MAXIMUM (20mA) <b>2000 PSI</b>	UP/DOWN to set the maximum sensor pressure. Ex: a 0-2000PSI sensor, enter 2000 here	Press SELECT to save
SENSOR MINIMUM (4mA) <b>0 PSI</b>	UP/DOWN to set the minimum sensor pressure. Ex: a 0-2000PSI sensor, enter 0 here	Press SELECT to save
APPLICATION: <b>PR REDUCING</b>	UP/DOWN to choose the application	Press SELECT to save
SV (SET VALUE): <b>920 PSI</b>	UP/DOWN to set the SET VALUE	Press SELECT to save
MODE: OFF <b>MANUAL</b>	UP/DOWN to move the pilot to MANUAL mode	Press SELECT to save
PSI <span style="float: right;">CO</span> <b>850</b> <span style="float: right;"><b>45.0%</b></span>	UP/DOWN to manually open the valve. Move Open the valve until you are about 5-10% below your setpoint.	Press SELECT to go back to the home screen
PV: <span style="float: right;"><b>850 PSI</b></span> SV: 920 <span style="float: right;">MAN 45.0%</span>	When the process appears stable, you can begin the autotune procedure	Press SELECT to go to the next screen
MODE: MANUAL <b>AUTOTUNE</b>	Press SELECT to begin the autotuning procedure	
PV: <span style="float: right;"><b>850 PSI</b></span> SV: 920 <span style="float: right;">A/T 45.0%</span>	The output will toggle high/low several times and monitor the output to calculate the internal gain of the system.	
PV: <span style="float: right;"><b>920 PSI</b></span> SV: 920 <span style="float: right;">RUN 53.7%</span>	After the constants have been determined, the PILOT will enter RUN mode and begin controlling the Output to meet setpoint.	

**GAP CONTROLLER APPLICATION**

SENSOR TYPE <b>PRESSURE</b>	Use the UP/DOWN Buttons to change the selection	Press SELECT to save
UNITS OF PRESSURE <b>PSI</b>	UP/DOWN to change the units to match your sensor	Press SELECT to save
SENSOR MAXIMUM (20mA) <b>2000 PSI</b>	UP/DOWN to set the maximum sensor pressure. Ex: a 0-2000PSI sensor, enter 2000 here	Press SELECT to save
SENSOR MINIMUM (4mA) <b>0 PSI</b>	UP/DOWN to set the minimum sensor pressure. Ex: a 0-2000PSI sensor, enter 0 here	Press SELECT to save
APPLICATION: <b>GAP CONTROL</b>	UP/DOWN to choose the application	Press SELECT to save
OPEN AT: <b>920 PSI</b>	UP/DOWN to set the OPEN SET VALUE	Press SELECT to save
CLOSE AT: <b>80 PSI</b>	UP/DOWN to set the CLOSE SET VALUE	Press SELECT to save
MODE: OFF <b>RUN</b>	UP/DOWN to move the pilot to RUN mode	Press SELECT to save
PV: <b>150 PSI</b> RUN GAP: 80/920 <b>100%</b>	The pilot will return to the home screen to display process value, units, set values, run mode, and controller output percentage.	

**7. User Interface**

Press the ENTER button to save the current value and move down to the next menu/sub-menu item.

Press the UP/DOWN buttons to change values or dig into the appropriate sub-menu.

Hold the ENTER button (approximately 3 seconds) to CANCEL the current input and return to the home screen.

Hold both the UP and DOWN buttons together (for approximately 3 seconds) to perform a factory reset.

		
FIRMWARE VERSION V06		
PV:100                      PSI RUN SV: 150                      85.0%		(Standard HOME screen)
PV:100                      PSI RUN G-T:750/100                      100%		Home Screen for Gap-Timer application
ON:1.25                      HR OFF:2.00                      RUN 100%		Home Screen for Timer Only application
	MODE: RUN	OFF, MANUAL, RUN, AUTOTUNE Use UP/DOWN buttons to select mode
	PSI                                      CO 103                                      85.2%	Controller Output - only available in MANUAL mode
SENSOR SETUP		
	SENSOR TYPE: PRESSURE	UNDEFINED (default), PRESSURE, FLOW, TEMPERATURE, LEVEL, TIMER - ONLY
	UNITS: PSI	Pressure: PSI, oz, mBAR, hPa, kPa, mm, in ,ft Flow: GPM, GAL, LPM, M3/D, M3, MGAL, FT3, M-L, MCF, MMCF, BBL, LBS, KGS Temperature: F, C LEVEL: m, ft, in, cm
	SENSOR MAX:                      20mA 150 PSI	Enter Number in range of ±32000
	SENSOR MIN:                      4mA 150 PSI	Enter Number in range of ±32000
CONTROL SETTINGS		
	APPLICATION: BK PRESSURE	PR REDUCING (PID DIRECT) BK PRESSURE (PID INDIRECT) HIGH LIMIT LOW LIMIT GAP CONTROL HIGH-LOW GAP TIMER TIMER ONLY
	SV (SET VALUE): 120 PSI	PID applications
	HIGH LIMIT SV: 100 PSI	HIGH-LOW or HIGH LIMIT application

**7. User Interface Continued**

	OPEN AT: 100 PSI	GAP or GAP-TIMER application
	HOLD OPEN TIME: 1.75 HR	GAP-TIMER or TIMER-ONLY applications. 0 to 125 HR in 0.25HR increments
	LOW LIMIT SV: 25 PSI	HIGH-LOW or LOW-LIMIT application
	CLOSE AT: 25 PSI	GAP or GAP-TIMER application
	HOLD CLOSE TIME: 1.75 HR	GAP-TIMER or TIMER-ONLY applications 0 to 125 HR in 0.25HR increments
SYSTEM DETAILS		
	INPUT VOLTAGE: 23.9V	
	HW TYPE/FW REV KA7509 v06	
COMM SETTINGS		
	RS485 BAUDRATE 9600	9600, 14400, 19200, 38400, or 57600
	RS485 DATABITS 8	
	RS485 PARITY NONE	NONE, ODD, or EVEN
	RS485 STOPBITS 1	1 or 2
	MODBUS ADDRESS 001	1 to 247
ADVANCED SETTINGS		See ADVANCED SETTINGS table

**Advanced Settings Table**

PID GAIN VALUES		
	KP 55e-04	Enter integer portion of Proportional Gain 0 to 100
	KP 55e-04	Enter exponent portion of Proportional Gain 0 to 8
	KI 34e-05	Enter integer portion of Integral Gain 0 to 100

**7. User Interface Continued**

	KI  34e-05	Enter exponent portion of Integral Gain 0 to 8
	KD  12e-05	Enter integer portion of Differential Gain 0 to 100
	KD  12e-05	Enter exponent portion of Differential Gain 0 to 8
PID RESET DAMPENING		
	RESET DAMPENING  ON	This helps prevent overshoot/undershoot from cold startup when SV is very far away from PV. It is ON by default with the following trip points
	100% SAMPLING  SV ± 20%	If PV is within 20% of SV, then integral will be added at every sample
	50% SAMPLING  SV ± 50%	If PV is only within 50% of SV, then integral will only be added every other sample
	25% SAMPLING  SV ± 80%	If PV is only within 80% of SV, then integral will only be added every fourth sample
AUTOTUNE PARAMETERS		
	CHANGE IN CO  CO ± 5%	This is the amount the actuator will change during autotune to force process oscillations. Valid entries are from 1 to 20%
	CHANGE IN PV  PV ± 2	This is the amount of change in PV that will trigger the actuator to toggle into the next direction. This value must be larger than system noise that is observed on PV, but less than the change in-CO can accomplish.
	PROCESS SPEED  MEDIUM	MEDIUM is the default value. By changing this, subsequent autotunes will calculate different gain values. Faster responses may cause oscillations and/or over/under-shoot.
CALIBRATE SENSOR IN		
	ANALOG INPUT: 4.0mA Hold UP to set 4mA Hold DN to set 20mA	This is available as an option but should NOT be needed. Factory calibration is acceptable in most applications. If further calibration is desired, be sure to use a precise loop calibrator in SIMULATE mode since the pilot already supplies loop power.
DISCRETE OUTPUT ON AT 20MA		ON at 20mA (Default) OFF at 20mA ON at 4mA OFF at 4mA DISABLED
MAN RST ON FAIL  OFF		Used for HIGH-LIMIT, LOW-LIMIT, HIGH-LOW applications only. ON – device will return to RUN mode when PV falls back within limits. OFF – device will remain OFF if a limit is reached and can only be reset with the discrete input or by entering back into RUN mode.
FACTORY RST HOLD UP/DN		

**8 Modbus Map**

Address	Description	R/W	Available command (hex)	Data Type	Acceptable Write Values	Notes
0	Device ID	R	03, 04	uint16		7509
1	Firmware Version	R	03, 04	uint16		06
2	Battery Voltage x10	R	03, 04	uint16		Implied decimal place (123 = 12.3VDC)
3	MB Address	R/W	03, 04, 06	uint16	1 (default) to 247	
4	Baudrate	R/W	03, 04, 06	uint16	9600 (default), 14400, 19200, 38400, 57600	
5	Databits	R	03, 04	uint16		8 databits only
6	Parity	R/W	03, 04, 06	uint16	0 = NONE (default) 1 = ODD 2 = EVEN	
7	Stopbits	R/W	03, 04, 06	uint16	1 (default) 2	
8	Run Mode	R/W	03, 04, 06	uint16	0 = OFF (default) 1 = RUN 2 = MANUAL 3 = AUTOTUNE	
9	Control Scheme	R/W	03, 04, 06	uint16	0 = UNDEFINED 1 = PID_DIRECT 2 = PID_INDIRECT 3 = HIGH LIMIT 4 = LOW LIMIT 5 = GAP CONTROL 6 = HIGH LOW 7 = GAP TIMER 8 = TIMER ONLY	Default: UNDEFINED
10	SV LOW x10	R/W	03, 04, 06	uint16	Sensor minimum to sensor maximum	Implied decimal place (500 = 50.0) Lower set value for LOW LIMIT, HIGH_LOW, GAP CONTROL, GAP TIMER Not used in the other control schemes
11	SV HIGH x10	R/W	03, 04, 06	uint16	Sensor minimum to sensor maximum	Implied decimal place (500 = 50.0) Set value used for all other control schemes Higher set value for HIGH LOW, GAP CONTROL or GAP TIMER
12	PV x10	R	03, 04	uint16		Implied decimal place (500 = 50.0) This is the measured process value
13	COx10	R	03, 04	uint16		Implied decimal place (500 = 50.0) This is the percentage open being demanded of the valve.
18	Integral Dampening	R/W	03, 04, 06	uint16	0 = OFF 1 = ON (default)	Used to enable or disable integral dampening when the process value is far away from the set value. This is used to prevent prolonged overshoot
20	Analog input x10	R	03,04	uint16		Implied decimal place: 120 = 12.0mA
21	Sensor Type	R/W	03, 04, 06	uint16	0 = PRESSURE 1 = FLOW 2 = TEMPERATURE 3 = LEVEL 4 = TIMER ONLY	Define the type of sensor being used
22	Input Units of process value	R/W	03, 04, 06	uint16	Depends on sensor type	Pressure: PSI, oz, mBAR, hPa, kPa, mm, in, ft Flow(GPM, GAL, LPM, L, M3/Day, M3, MGal, Ft3, MLiters, MCF, MMCF, BBL, LBS, KGS Temperature: F, C Level: m, ft, in, cm
23	Sensor 4mA	R/W	03, 04, 06	int16	±32000	Process value that correlates to 4mA signal

## 8 Modbus Map continued

Address	Description	R/W	Available command (hex)	Data Type	Acceptable Write Values	Notes
24	Sensor 20mA	R/W	03, 04, 06	int16	±32000	Process value that correlates to 20mA signal
30	Discrete output status	R	03, 04	uint16		0 = OFF 1 = ON
32	Discrete input status	R	03, 04	uint16		0 = OFF 1 = ON
33	Manual Reset on Fail	R/W	03, 04, 06	uint16	0 = Auto Reset 1 = Manual Reset	0 = OFF 1 = ON
34	Discrete Output Function	R/W	03, 04, 06	uint16	0 = ON at 20mA 1 = OFF at 20mA 2 = ON at 4mA 3 = OFF at 4mA 4 = Disabled	Default: ON at 20mA Discrete output will apply VIN voltage to the DOUT pin when ON. Can be used to control a solenoid or signal an alarm that the valve is open or closed.
40	Analog output x 10	R	03, 04	uint16		Implied decimal place (125 = 12.5mA) Analog value being sent to the valve
50	Open time	R/W	03, 04, 06	uint16	0-12500	Implied decimal place (125 = 1.25HR). Value must be in increments of 0.25 HR Time to hold the valve open for GAP-TIMER and TIMER-ONLY applications.
51	Close time	R/W	03, 04, 06	uint16	0-12500	Implied decimal place (125 = 1.25HR). Value must be in increments of 0.25 HR Time to hold the valve close for GAP-TIMER and TIMER-ONLY applications.
70	KP-int	R/W	03, 04, 06	uint16	0-100	Scaled proportional constant $K_P = K_{P\_INT} * 10^{-K_{Pscale}}$
71	KP-scale	R/W	03, 04, 06	uint16	0-8	Scaled proportional constant $K_P = K_{P\_INT} * 10^{-K_{Pscale}}$
72	KI-int	R/W	03, 04, 06	uint16	0-100	Scaled proportional constant $K_I = K_{I\_INT} * 10^{-K_{Iscale}}$
73	KI-scale	R/W	03, 04, 06	uint16	0-8	Scaled proportional constant $K_I = K_{I\_INT} * 10^{-K_{Iscale}}$
74	KD-int	R/W	03, 04, 06	uint16	0-100	Scaled proportional constant $K_D = K_{D\_INT} * 10^{-K_{Dscale}}$
75	KD-scale	R/W	03, 04, 06	uint16	0-8	Scaled proportional constant $K_D = K_{D\_INT} * 10^{-K_{Dscale}}$
140	Kp	R/W	03, 04, 16	float32		Proportional Constant: 32bit floating point value
142	Ki	R/W	03, 04, 16	float32		Integral Constant: 32bit floating point value
144	Kd	R/W	03, 04, 16	float32		Derivative Constant: 32bit floating point value
146	Process speed for AUTOTUNE calculation	R/W	03, 04, 06	uint32	1, 2, 3, or 4	Default is 3. Provides some scaling while calculating the gain constants during AUTOTUNE. Higher numbers will slow down the PID response, lower numbers will speed it up.
152	Change in PV during AUTOTUNE	R/W	03, 04, 06	float32		Implied decimal place. 100 = 10.0 PSI Amount of change in process value before bumping the other direction Default is calculated as 1.5% of the total sensor range
154	Change in CO during AUTOTUNE	R/W	03, 04, 06	float32	1	Implied decimal place 50 = 5.0% Amount of change in the controller output to create a change in process value Default is 5%

Command:

03: Modbus read single holding register

04: Modbus read single input register

06: Modbus write single holding register

16: Modbus write multiple holding register



## 9 DISASSEMBLY

1. Once power has been removed from all wiring, unscrew the cover cap from the enclosure.
2. Remove the four screws holding the board to the stand-offs.
3. Remove the wiring from the board – labeling each wire if not already done so.

## 10 ASSEMBLY

1. Install the appropriate wires to each terminal of the board – label or mark the wires as appropriate.
2. Gently tuck excess wire into the cavity behind the board while lining the board up with the standoffs
3. Fasten the board to the standoffs using the provided hex-cap screws.
4. Close and tighten the cover cap to the housing.

## 11 TROUBLESHOOTING

Problem	Possible Cause(s)	Possible Solution
Valve does not respond to pilot output signal Ex. The Kimray TRITEX RE-QUIRES a 24V loop voltage, even if the TRITEX is running at 12V.	Output analog loop may not be sufficient to drive the actuator.	Operate the pilot with 24VDC to force the analog loop voltage to 24V
Valve does not open all the way even though the pilot indicates 100% (20mA) output	Input voltage may be low. The isolation methods used to generate its own loop voltage requires 2.5V of headroom. Measure Voltage from AIN+ to AIN- terminals and verify the sensor can operate at that level.	Increase VIN
The input signal appears to be incorrect	The sensor might be hooked up backwards. If the green LOOP light is off on the pilot, then the sensor is not hooked up correctly	Correct the sensor wiring
	The sensor might not be getting enough loop voltage. Measure the Voltage from AIN+ to AIN- terminals and verify that the sensor can operate at those levels	Increase VIN or use a lower voltage sensor.



## EU Declaration of Conformity

Model: KEP, Kimray Electric Pilot

We, the manufacturer,  
**Kimray, Inc.**  
52 NW 42<sup>nd</sup> St  
Oklahoma City, Oklahoma, 73118, USA

Declare under our sole responsibility that the following product(s)

**Kimray Electric Pilot**

to which this declaration relates, is in conformity with the provision of the following European Community Directives, including the latest amendments, as shown as in the attached schedule. Assumption of conformity is based on the application of the harmonized standards and, when applicable or required, a European Community Notified Body certification, as shown in the attached schedule.

Ky Longley  
Principle Electronic Design Engineer  
52 NW 42<sup>nd</sup> St  
Oklahoma City, OK, 73118

3/21/2023

Date:

**ATEX Directive – 2014/34/EU (Applicable only if this mark  appears on the product)**

Certificate – CSANe 22ATEX1058X -- Group II Category 2GD– Flameproof  
Kimray Electric Pilot

Ex db IIC T6 Gb

Standards used: EN60079-0:2018, EN60079-1:2014, EN60079-31:2014

**ATEX Notified Body (for EC Type Examination) Certificate(s)**

CSA Group – Notified Body Number: 2813  
8501 East Pleasant Valley Rd.  
Cleveland, Ohio 44131-5516, USA

**ATEX Notified Body for Quality Assurance**

CSA Group Netherlands B.V. – Notified Body Number: 2813  
Utrechtseweg 310, Building B42,  
6817AR Arnhem, The Netherlands

Kimray is an ISO 9001- certified manufacturer.  
Kimray quality assurance process maintains strict controls  
of materials and the certification of parts used in the Kimray Electric Burner Valve.

Please visit our website for up to date product data [www.kimray.com](http://www.kimray.com)

# WHO WE ARE

Kimray designs and manufactures oil and gas control products. Based on more than 65 years of pioneering product development, we provide products and services that are reliable, smart and inventive. We generate meaningful solutions by staying curious and engaging in customers' needs. Our product ideas are fueled by a deep desire to make a difference that is both personal and unique to the customer.

We have made it our life's work to provide products and services that are positively impactful. Through the years, this pursuit has built strong relationships. Our customers have known that buying from Kimray is about much more than the product. The relationships between Kimray representatives and our customers extend from before the sale through the life of the product. Those relationships, along with quality Kimray products, are the result of a company striving for excellence for our customers, our company and our community.

Visit [Kimray.com](http://Kimray.com) to learn more about our company and the products we create.



[Kimray.com](http://Kimray.com)

