

**KIMRAY**  
INC.®

INSTALLATION  
OPERATION &  
MAINTENANCE  
**GUIDE**



**E-LO CONTROL VALVE**

All Rights Reserved.

All contents of this publication including illustrations are believed to be reliable. And while efforts have been made to ensure their accuracy, they are not to be construed as warranties for guarantees, express or implied, regarding Kimray products or services described herein or their use or application. All sales are governed by our terms and conditions, which are available on request.

Kimray reserves the right to modify or improve the designs or specifications of such products at any time without prior notice.

©2016 Kimray Inc.

# Contents

<b>A</b>	<b>Before you start</b> .....	<b>4</b>
	A1 Scope.....	4
	A2 Introduction.....	4
	A3 Description.....	4
	A4 Maintenance.....	4
	A5 Changes and Updates.....	4
	A6 Special Tools and Equipment.....	5
	A7 Non Hazards Location Orientation.....	6
	A7 Hazards Location Approved Orientation.....	6
<b>1</b>	<b>Installation</b> .....	<b>8</b>
<b>2</b>	<b>Start-up and Test</b> .....	<b>8</b>
<b>3</b>	<b>Analog Module Calibration</b> .....	<b>8</b>
<b>4</b>	<b>Wiring Diagrams</b> .....	<b>9</b>
<b>5</b>	<b>Modbus Map</b> .....	<b>10</b>
	<b>DISASSEMBLY</b>	
<b>6</b>	<b>Disassembly</b> .....	<b>11</b>
	<b>ASSEMBLY</b>	
<b>7</b>	<b>Assembly</b> .....	<b>12</b>
	<b>TROUBLESHOOTING</b>	
<b>8</b>	<b>Troubleshooting Table</b> .....	<b>13</b>

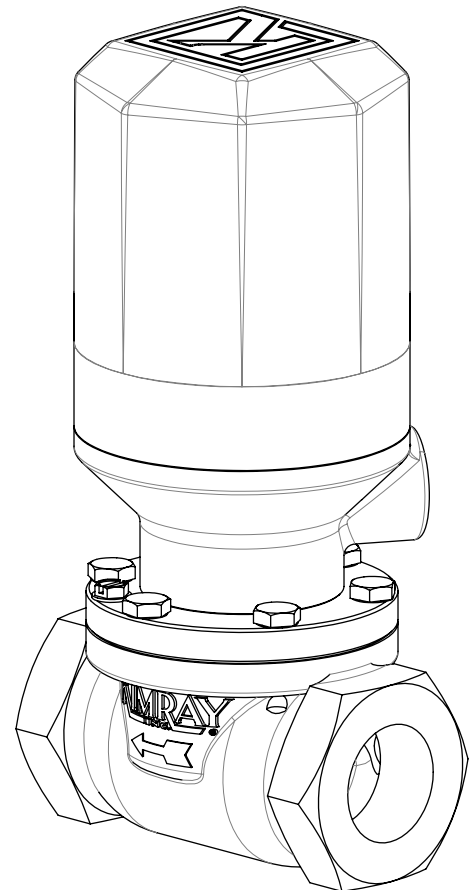

### A Before you start

#### CAUTION:

Prior to installing, the instructions provided herein should be completely reviewed and understood before operating or repairing this equipment. All CAUTION and WARNING notes must be strictly observed to prevent personal injury or equipment damage.

#### A1 Scope

Do not install, operate, or maintain an E-Lo Control Valve without being fully trained and qualified with the Kimray installation and maintenance manual. To avoid personal injury or property damage, it is important to carefully read, understand, and follow all the contents of this manual, including all safety cautions and warnings. If you have any questions about these instructions, contact your Kimray applications support group before proceeding.

#### A2 Introduction

This installation manual includes instructions and maintenance information for the Kimray E-Lo Control Valve.

#### A3 Description

The Kimray E-Lo Control Valve is designed primarily to control flow of low pressure (<45 psig) fuel gas within burner systems. This valve is ideal for applications within the oil and gas production industry, specifically heater treaters, line heaters, incinerators, combustors and glycol dehydrators.

#### A4 Maintenance

Maintenance should be performed on a regular basis. An initial inspection interval of 12 months is recommended. Depending on the service conditions of the valve, the inspection interval may be decreased.

#### WARNING:

A leaking valve is an indication that service is required. Failure to take valve out of service immediately may cause a hazardous condition.

#### WARNING:

Before any service, be certain that the valve is fully isolated and that all pressure upstream and downstream has been relieved. Use bypass valves or fully shut off the process.

Never assume that a check valve is fully blocking the downstream line.

Never tighten any fitting or the main connections to a valve while pressure is applied.

#### WARNING:

**DO NOT** remove the actuator from the valve while the valve is still pressurized.

Always wear protective gloves, clothing, and eyewear when performing any maintenance operations to avoid personal injury.

Disconnect any operating lines providing electric power, or a control signal to the actuator. Be sure the actuator cannot suddenly open or close the valve.

Use bypass valves or completely shut off the process to isolate the valve from process pressure. Relieve process pressure on both sides of the valve. Drain the process media from both sides of the valve.

Use lock-out procedures to be sure that the above measures stay in effect while you work on the equipment.

#### Related Publications

The following publications are applicable for the actuator. See catalog section E2 for product pages.

#### Abbreviations / Acronyms

The abbreviations that follow are used in this manual.

Term	Definition
------	------------

#### Commonly Replaced Parts

#### Occasional Replacement Parts

See repair kit

#### A5 Changes and Updates

5/2017 Rebrand "Electric Burner Valve" with "E-Lo Control Valve"

**A6 SPECIAL TOOLS AND EQUIPMENT**

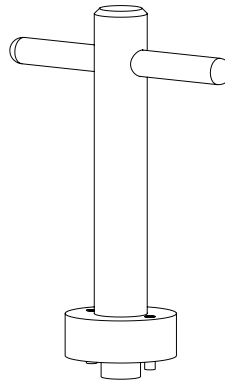

*Kimray Seat Wrenches  
Part # 1349SW*

### A7 ORIENTATION Non Hazardous Location

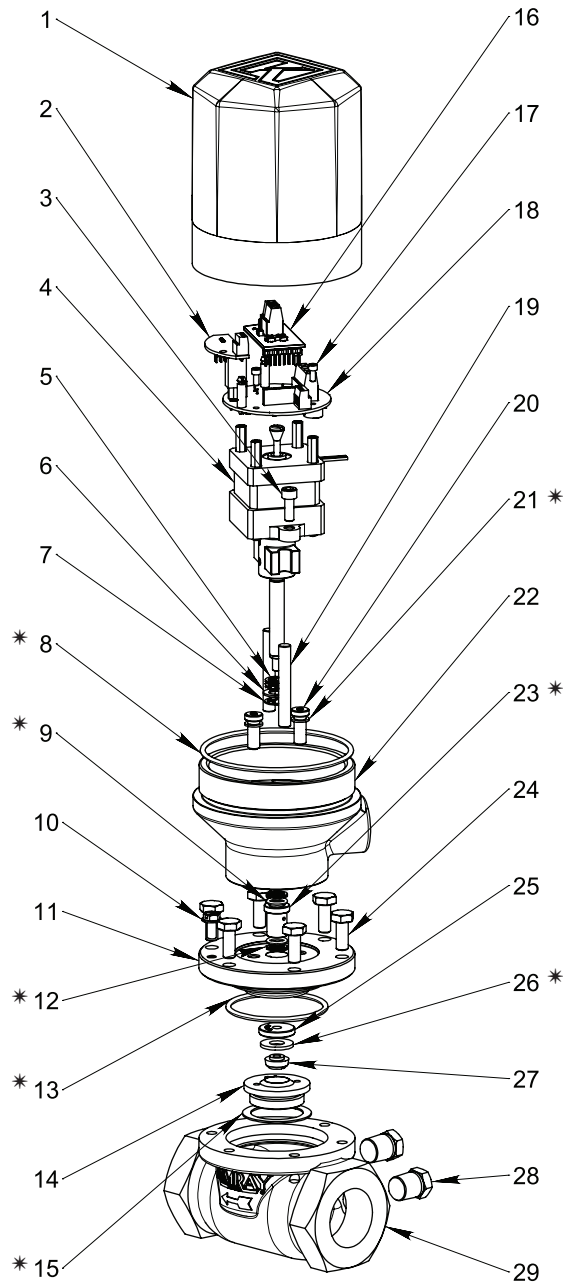

\* Recommended spare parts and stocked as repair kits

Item	Description	Qty
1	Enclosure Cover	1
2	Modbus Module	1
3	Screw	2
4	Motor Assembly	1
5	Spring	1
6	Washer	1
7	E Ring	1
8	O'Ring *	1
9	O'Ring *	2
10	Ground Screw	1

Item	Description	Qty
11	Bonnet	1
12	Back up *	2
13	O'Ring *	1
14	Removable Seat	1
15	Gasket *	1
16	Input Module	1
17	Screw	4
18	Main PCB	1
19	Guide Pin	2
20	Screw	2

Item	Description	Qty
21	Poly Washer *	2
22	Enclosure	1
23	Stem Bushing *	1
24	Screw	6
25	Seat Disc	1
26	Seat *	1
27	Ratio Plug	1
28	Plug	2
29	Body	1

Kimray reserves the right to modify or improve the designs or specifications of such products at anytime without notice.

### A7 ORIENTATION Hazardous Location Approved

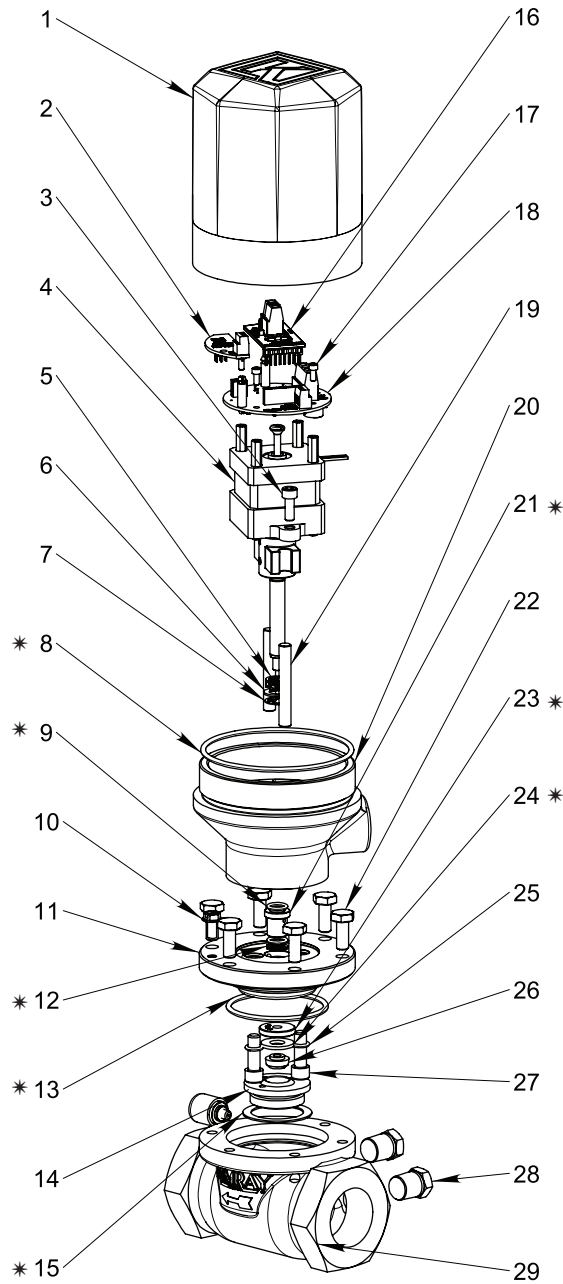

\* Recommended spare parts and stocked as repair kits

Item	Description	Qty
1	Enclosure Cover	1
2	Modbus Module	1
3	Screw	2
4	Motor Assembly	1
5	Spring	1
6	Washer	1
7	E Ring	1
8	O'Ring *	1
9	O'Ring *	2
10	Ground Screw	1

Item	Description	Qty
11	Bonnet	1
12	Back up *	2
13	O'Ring *	1
14	Removable Seat	1
15	Gasket *	1
16	Input Module	1
17	Screw	4
18	Main PCB	1
19	Guide Pin	2
20	Enclosure	1

Item	Description	Qty
21	Stem Bushing *	1
22	Screw	6
23	Seat Disc *	1
24	Seat *	1
25	Poly Washer	2
26	Ratio Plug	1
27	Screw	2
28	Plug	2
29	Body	1

## 1 Installation

### Valve Installation:

Before installing the E-Lo Control Valve, inspect it for shipment damage and for foreign material that may have collected during shipment. Inspect the openings in the valve and clean the pipe lines to remove scale, chips and debris.

Verify all pressure connections are tight before pressurizing the system.

1. Be sure you fully understand the application, operation and connection of the device before installing.
2. Install the valve with the arrow on the body pointing in the direction of flow. The arrow signifies that the device will operate properly in the direction of flow as indicated and will not necessarily prevent flow in the opposite direction.

NOTE: If conditions indicate the possibility of backward flow you may wish to install check valves.

3. Install the valve using good piping practices. For flanged bodies use a suitable gasket between the body and the pipeline flanges. For threaded (NPT) bodies, use TFE tape or pipe thread sealant on external pipe threads. The flanged valve bodies are rated ANSI class 150RF. Do not install the valve in a system where the working pressure can exceed ANSI class ratings.

### Wiring Instructions:



#### NOTE:

Use good electrical wiring practices and consult with electrician.

### Power Requirements

Ensure a stable DC power source is available for the application. A 600mA (minimum) power supply is required. Voltage can be anywhere in the range from 10 to 30 VDC

### Wiring Instructions

1. Observe local wiring requirements for hazardous location usage.
2. Conduit seals within 18 inches of the enclosure port are required for explosion-proof installation.
3. Fuse input power to 1A
4. Wire size requirements:
  - Power 12 AWG to 20 AWG
  - Discrete input 12 AWG to 20 AWG
  - Analog input 12 AWG to 20 AWG
  - RS485 input 16 AWG to 30 AWG
5. Ensure power is off before connection or removing wires or modules

## 2 Start-up and Test



#### WARNING:

Follow strict safety precautions when energizing and de-energizing any system. Permits may be required when commissioning or performing maintenance of electrical devices. Live circuits may generate a spark necessary to ignite flammable or combustible gas and vapors.

1. Before applying power to the valve, ensure a 'close' signal is provided to the input.
2. Apply power to the valve.



#### NOTE:

Valve will close upon power-up. A buzzing noise is normal as the valve drives to full closure.

3. Provide a change in position demand and ensure the valve responds appropriately.
4. If the valve does not respond appropriately, please refer to the "Troubleshooting" section.
5. Check conduit ports for proper seal.
6. Install the enclosure cap until firmly seated against the enclosure body.
7. Slowly open the downstream isolation valve and check for leaks. Repeat the process for the upstream isolation valve.

If a leak is detected:

1. Remove power to the device.
2. Isolate the device and bleed any pressure remaining on the system.
3. Address the leak as necessary by applying sealant to NPT threads, replacing gaskets or O'Rings and ensuring all fasteners are properly tightened.
4. Repeat the start-up procedure.

## 3 Analog Module Calibration



NOTE: The analog module comes pre-calibrated from the factory.

If further refinement is needed, the user can also perform a field calibration using the following method:

- 1) Install the analog module into the control valve.
- 2) Apply power to the control valve.
- 3) Apply 4mA to the analog module.
- 4) Hold down on the button labeled "4mA" until the red status LED lights up.
- 5) Apply 20mA to the analog module.
- 6) Hold down on the button labeled "20mA" until the red status LED lights up.



#### 4 Wiring Diagrams

##### Main Board

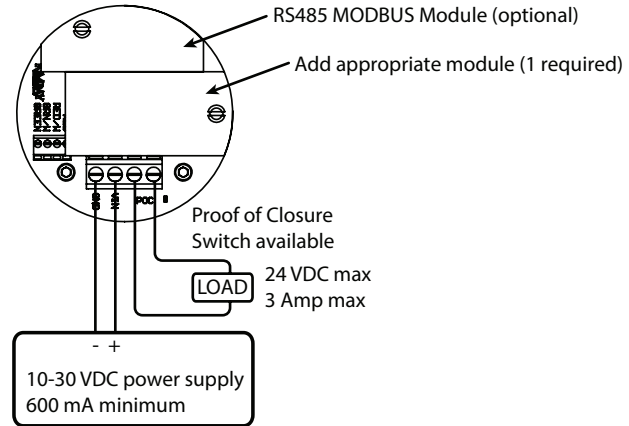

##### Discrete

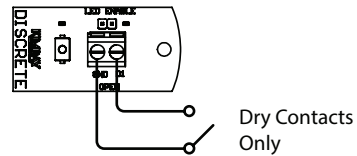

##### Analog

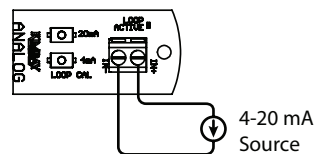

##### RS485

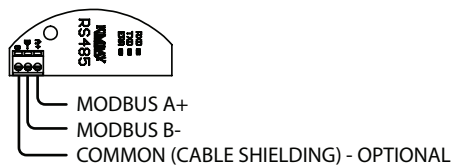

### 5 Modbus Map

An optional RS485 module is available to add MODBUS RTU capability to the control valve. To add MODBUS to the Kimray E-Lo Control Valve, simply plug in the RS-485 module and connect the appropriate signals from any RS485 master

Address	Description	R/W	Available command (hex)	Data Type	Acceptable Write Values	Notes
0	Percent open	R	03, 04	uint16	---	Implied decimal place (1000 = 100.0%)
1	Proof of closure switch	R	03, 04	uint16	---	0 = Valve is not fully closed 1 = Valve is fully closed
2	Battery Voltage	R	03, 04	uint16	---	Implied decimal place (12.3 = 12.3VDC)
3	Firmware Version	R	03, 04	uint16	---	
4	MB Address	R	03, 04	uint16	---	Currently fixed at address 0x01
5	Baudrate	R	03, 04	uint16	---	Currently fixed at 9600 baud
6	databits	R	03, 04	uint16	---	Size of databit is 8 for MODBUS RTU
7	Parity	R	03, 04	uint16	---	0 = parity NONE (currently fixed at 0) 1 = parity ODD 2 = parity EVEN
8	Stopbits	R	03, 04	uint16	---	Current fixed at 1
20	Analog input	R	03, 04	uint16	---	Implied decimal place. 45 = 4.5mA
21	Analog shutoff	R/W	03, 04, 06	uint16	0 to 74	Implied decimal place (25 = 2.5%) Below this value, the E-Lo will close tightly. Factory Default = 15 1.5% of the 4-20mA range => 4.2mA
30	Discrete input Switch	R	03, 04	uint16	---	0 = OPEN – no discrete signal applied 1 = CLOSED – discrete signal is present
31	Manual input Switch	R	03, 04	uint16	---	0 = OPEN – no discrete signal applied 1 = CLOSED – discrete signal is present
161	Analog 4mA CAL	R/W	03, 04, 06	uint16	0 to 4095	ADC value of 4mA calibration setting Factory Default = 786
162	Analog 20mA CAL	R/W	03, 04, 06	uint16	0 to 4095	ADC value of 20mA calibration setting Factory Default = 3932
177	Open Velocity	R/W	03, 04, 06	uint16	0 to 1023	Relative speed to open the valve Factory Default = 1023 (about 5 seconds)
178	Close Velocity	R/W	03, 04, 06	uint16	0 to 1023	Relative speed to close the valve Factory Default = 0 (about 1.5 seconds)
Command: 03: Modbus read single holding register 04: Modbus read single input register 06: Modbus write single holding register						

## **6 DISASSEMBLY**

1. Once the system has been de-energized of pressure and electricity, remove the enclosure cover and disconnect the input wires.
2. Remove the (6) bonnet cover bolts and carefully remove the electrical enclosure and bonnet assembly.
3. Remove the ratio plug, rubber seat and seat disc.
4. Remove the (2) screws on the motor flange and separate the motor from the enclosure by gently pulling the shaft through the enclosure assembly.
5. Remove the (2) guide pins from the enclosure body.
6. Remove the (2) socket head screws and poly washers inside the enclosure to separate the enclosure body from the bonnet.
7. With a small pick, remove the guide bushing, O'Rings and backups from the bonnet and enclosure.
8. Carefully remove the E-clip, washer and spring from the motor assembly.
9. With the proper spanner wrench, unscrew the seat from the body. If the seat gasket remains in the body, remove and clean the gasket surfaces to remove any residue.

### 7 ASSEMBLY

1. Install the seat gasket onto the seat. Apply grease to the gasket and screw the seat into the body with the proper spanner wrench.
2. Install O'Rings and backups into the bonnet and enclosure body and apply a small amount of oil to the seals. Insert the stem bushing into the bonnet.
3. Align the bonnet and enclosure housing and secure with (2) screws and poly washers.
4. Install the spring, washer and E-clip onto the valve stem.
5. Insert the (2) guide pins into the enclosure body.
6. Insert the valve stem through the enclosure and secure the motor assembly with (2) screws. The anti-rotation guide must be installed between the guide pins.
7. Install the seat disc, rubber seat and ratio plug with a small amount of threadlocker.
8. Align the bonnet onto the body and install with (6) cap screws and torque to 10 ft-lb.
9. Connect all input wires and test for functionality.
10. Install enclosure cover until seated firmly onto the enclosure body.

**8 TROUBLESHOOTING**

<b>Problem</b>	<b>Possible Cause(s)</b>	<b>Possible Solution</b>
Valve flows to downstream when it should be closed	Close signal not provided	Check signal from input device
	Obstruction in valve	Remove obstruction
	Input pressure too high	Reduce input pressure to appropriate level
	Rubber seat is worn	Replace rubber seat
Power is applied to valve, but it does not operate	Input voltage polarity is reversed	Check polarity and correct if necessary
	Fuse is blown	Check fuse. If blown, investigate cause.
Valve does not track with analog signal	Is analog signal connected properly?	Check "Loop Active". Will be brighter at 20mA than 4mA.
	Does analog input need to be calibrated?	Calibrate input according to installation instructions
	Has analog input module become damaged?	Replace module and verify operation.
Valve does not track with Discrete Input signal	Does valve open with manual button input, but not with discrete input?	Verify that the discrete input is working properly.
	Discrete input has been verified, but valve does not respond.	Replace module and verify operation.
Modbus communication is not working.	Are communication settings correct? Check LEDs for receive/transmit activity.	Factory default is Modbus address 1, 9600 baud, 8 databits, none parity, 1 stopbit.
	Has Modbus module become damaged?	Replace module and verify operation.

**Page left blank**

Kimray is an ISO 9001- certified manufacturer.  
Kimray quality assurance process maintains strict controls  
of materials and the certification of parts used in the Kimray Electric Burner Valve.

Please visit our website for up to date product data [www.kimray.com](http://www.kimray.com)

# WHO WE ARE

Kimray designs and manufactures oil and gas control products. Based on more than 65 years of pioneering product development, we provide products and services that are reliable, smart and inventive. We generate meaningful solutions by staying curious and engaging in customers' needs. Our product ideas are fueled by a deep desire to make a difference that is both personal and unique to the customer.

We have made it our life's work to provide products and services that are positively impactful. Through the years, this pursuit has built strong relationships. Our customers have known that buying from Kimray is about much more than the product. The relationships between Kimray representatives and our customers extend from before the sale through the life of the product. Those relationships, along with quality Kimray products, are the result of a company striving for excellence for our customers, our company and our community.

Visit [Kimray.com](http://Kimray.com) to learn more about our company and the products we create.



[Kimray.com](http://Kimray.com)

