

KIMRAY
INC.®

INSTALLATION
OPERATION &
MAINTENANCE
GUIDE



HIGH PRESSURE CONTROL VALVE
STEM GUIDED

All Rights Reserved.

All contents of this publication including illustrations are believed to be reliable. And while efforts have been made to ensure their accuracy, they are not to be construed as warranties for guarantees, express or implied, regarding Kimray products or services described herein or their use or application. All sales are governed by our terms and conditions, which are available on request.

Kimray reserves the right to modify or improve the designs or specifications of such products at any time without prior notice.

©2015 Kimray Inc.

Contents

A	Before you start	4
A1	Scope.....	4
A2	Introduction.....	4
A3	Description.....	4
A4	Maintenance.....	4
A5	Changes and Updates.....	4
A6	Special Tools and Equipment.....	5
A7	Orientation.....	6
INSTALLATION		
1	Installation	7
2	Start-up and Test	7
DISASSEMBLY		
3	Adjusting Screw, Pivot, Breather Plug, Bonnet	8
4	Travel Indicator	9
5	Pivot, Spring Plate, Spring	9
6	Pivot Sleeve, Diaphragm Plate, Diaphragm Nut	10
7	Yoke Assembly	11
8	Packing Box	12
9	Removing Packing Box	13
10	Packing Box Assembly	14
INSPECTION		
11	Inspection & Cleaning	15
ASSEMBLY		
12	Cage Packing	16
13	Diaphragm Assembly	18
14	Internal Yoke Assembly	19
15	Pressure Closed	20
16	Travel Indicator	21
TESTING		
17	High Pressure Control Valve Test	22

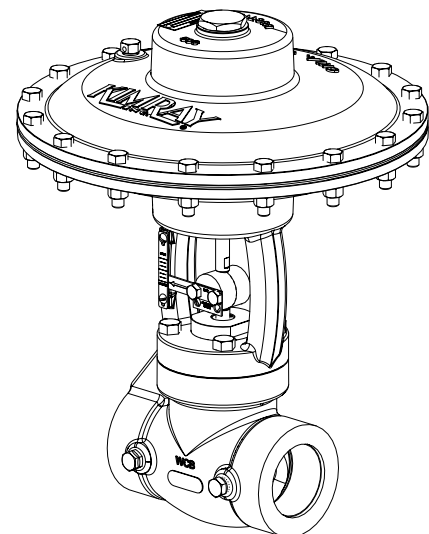

Model: PO, PC

Installation, Operation & Maintenance Guide

A Before you start

CAUTION:

The instructions provided herein should be completely reviewed and understood before operating or repairing this equipment. All CAUTION and WARNING notes must be strictly observed to prevent personal injury or equipment damage.

A1 Scope

Do not install, operate, or maintain a control valve without being fully trained and qualified with the Kimray installation operation and maintenance manual.

To avoid personal injury or property damage, it is important to carefully read, understand, and follow all the contents of this manual, including all safety CAUTION's and WARNING's.

If you have any questions about this manual, contact your Kimray applications support group before proceeding.

A2 Introduction

This repair manual contains information for the PO, PC, PC, High Pressure Control Valve.

A3 Description

The Kimray High Pressure Control Valve (HPCV) is designed for use in liquid and gas control applications which require modulating (throttling) or on/off service.

The HPCV has a single port Body and a pneumatic spring actuator. This actuator is available in either pressure open PO (normally closed), or pressure closing actuators.

Because of the high pressure range, a Packing Box houses a non adjustable spring loaded teflon sleeve around the Stem with a Felt Wiper and Buna Back Ups for leak free sealing.

CAUTION:

When ordered, the HPCV configuration and construction materials were selected to meet specific pressure, temperature, pressure drop and fluid conditions. Since some Body / trim material combinations are limited in their pressure drop and temperature ranges, do not subject the pressure regulator to any other conditions without first contacting the Kimray Inc, sales office or a sales / applications representative.

WARNING:

DO NOT exceed the maximum pressure specified on the nameplate. Under no circumstances should the regulator supply pressure ever exceed the maximum psig.

A4 Maintenance

Maintenance should be performed on a regular basis. Initial intervals of 12 months is recommended. The maintenance interval may increase or decrease depending on changing application environments. The valve can be repaired without being removed from the piping.

Related Publications

The following publications are applicable for the regulator

Number	Type	Title
--------	------	-------

See catalog section E1 for product pages.

Abbreviations / Acronyms

The abbreviations that follow are used in this manual.

Term	Definition
PO	Pressure Open
PC	Pressure Closed

Commonly Replaced Parts

- Trim Set
- Diaphragm
- O-Ring
- Packing

Occasional Replacement Parts

- Body
- Spring

A5 Changes and Updates

NOTE:

To prevent galling or seizing at assembly level for straight threads Kimray recommends using a nickel impregnated paste. For other threads use a nickel impregnated PTFE thread sealant tape.

SPECIAL TOOLS AND EQUIPMENT

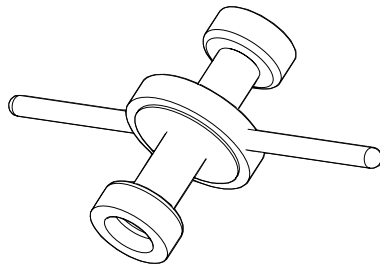

Kimray Seat & Cage Removal Tool	
Part No.	Line Size
3032	1 in.
3033	2 in.

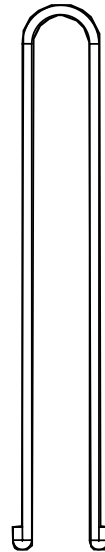

Kimray Seat Removal Tool	
Part No.	Line Size
615	1 in.
614	2 in.

A6



Tip:

Kimray recommends using the above special tools and equipment for disassembly, assembly and new part replacements.

HIGH PRESSURE CONTROL VALVE



Model: PO, PC

Installation, Operation & Maintenance Guide

ORIENTATION Stem Guided Shown

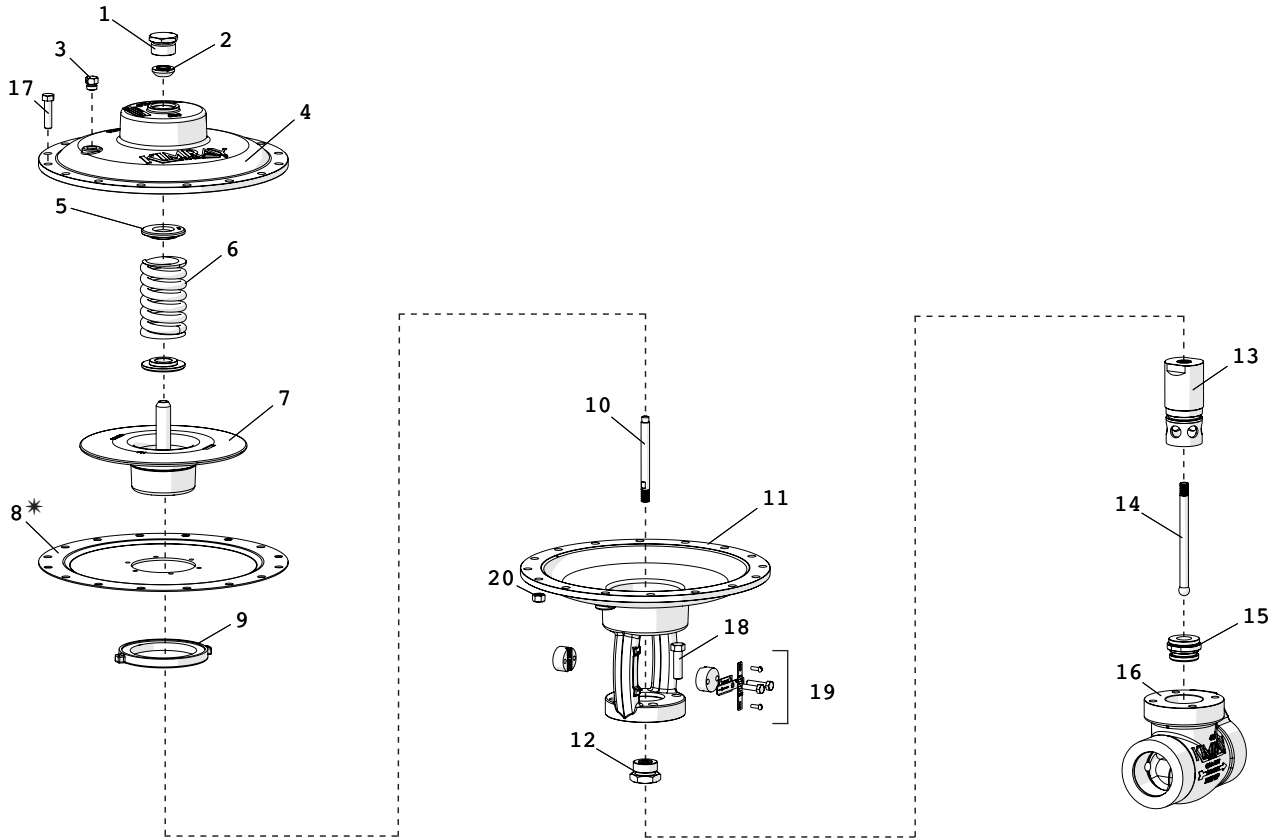

A7

* Recommended spare parts and stocked as repair kits
See catalog section E1 for additional information

Item	Part No. / Description	Qty	Item	Part No. / Description	Qty
1	Adjusting Screw	1	11	Yoke	1
2	Pivot	1	12	Lower Adjusting Screw	1
3	Breather Plug	1	13	Packing Box	1
4	Bonnet	1	14	Lower Stem	1
5	Spring Plate	2	15	Seat	1
6	Spring	1	16	Body	1
7	Diaphragm Plate	1	17	Screw	16
8	Diaphragm *	1	18	Screw	4
9	Diaphragm Nut	1	19	Travel Indicator Assembly	1
10	Upper Stem	1	20	Nut	16

1 Installation

Before installing the control valve, inspect it for shipment damage and for foreign material that may have collected during shipment. Inspect the openings in the valve and clean the pipe lines to remove scale, chips and debris.

1. Install the valve with the arrow on the body pointing in the direction of flow. The arrow indicates that the direction of flow and will not necessarily prevent flow in the opposite direction.

The flow direction of the HPCV PB is up through the valve. The stem guided trim is down through the valve. If conditions indicate the possibility of back word flow, you may wish to install check valves.

2. Install the valve using good piping practice. For flanged bodies remove the masking sticker from the raised face of each end connection & use a suitable gasket between the body and the pipeline flanges. For threaded (NPT) bodies, use TFE Tape or pipe thread sealant on external pipe threads.
3. Connect instrument gas to the actuator connection. The maximum required instrument gas pressure is 30 psig (2 bar); 45 psig (3 bar) is permissible.



NOTE:

Always check fastener tightness prior to valve installation, testing, and use, as fasteners have the potential to loosen in transit. This is recommended to ensure your safety and proper valve function.

Kimray assembly torque method below

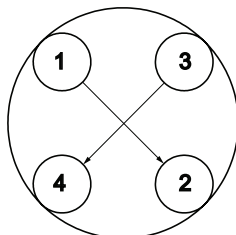

Four Bolt

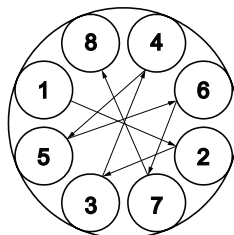

Eight Bolt

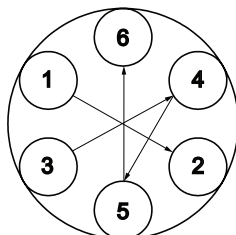

Six Bolt

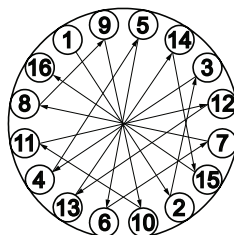

Sixteen Bolt



CAUTION:

When ordered, the high pressure valve configuration and construction materials were selected to meet specific pressure, temperature, pressure drop and fluid conditions. Since some body/trim material combinations are limited in their pressure drop and temperature ranges, DO NOT subject the high pressure valve to any other conditions without first contacting the Kimray Inc, sales office or a sales/applications representative.

2 Start-up and Test

With the installation completed and appropriate relief and check valves installed and set, slowly open the upstream and downstream shutoff valves. In order to test the function of the valve, allow only a small amount of upstream fluid to flow through the upstream shutoff valve. Check for proper valve operation by cycling the actuator arm several times.



WARNING:

DO NOT exceed the maximum supply pressure specified on the HPCV nameplate. Under no circumstances should the HPCV supply pressure ever exceed the maximum psig.

Pressure Opening Valve

Remove the plastic stopper from the tapped hole in the underside of the bonnet. Install a 1/4" or 3/8" tube fitting (not provided). The tubing must be installed from your source of instrument gas. The fitting at the top of the bonnet is a Breather Plug.

Pressure Closing Valve

Remove the plastic stopper from the tapped hole in the top side of the bonnet. Install a 1/4" or 3/8" tube fitting (not provided).

The tubing must be installed from your source of instrument gas. The fitting in the lower half of the bonnet is a Breather Plug.



NOTE:

Never stand directly over or in front of a valve when the system is pressurized. The valve could suddenly open, blowing debris into the person's face and eyes.



WARNING:

Before any service, be certain that the valve is fully isolated and that all pressure upstream and downstream has been relieved. Use bypass valves or fully shut off the process. Be sure that any operating or instrument gas lines has been disconnected. Never assume that a check valve is fully blocking the downstream line. Never tighten any fitting or the main connections to the regulator while there is pressure on the line. A leaking valve indicates that service is required. Failure to take the valve out of service immediately may create a hazardous condition.

Verify all pressure connections are tight before pressurizing the system.



NOTE:

When a gasket seat is disturbed during disassembly a new gasket should be installed during re-assembly to ensure proper sealing.

Repair kits are available. contacting the Kimray Inc, sales office or a sales/applications representative for the correct repair kit number.

Model: PO, PC

Installation, Operation & Maintenance Guide

DISASSEMBLY

3 Adjusting Screw, Pivot, Breather Plug, Bonnet

Use a wrench to remove the Adjusting Screw on top of the Bonnet. See Fig. 3-1

Remove Pivot from Adjusting Screw. See Fig. 3-2



NOTE:

Sometimes the Pivot will separate from the Adjusting Screw and sit on top of the Spring Plate.

Remove the Breather Plug from Bonnet. See Fig. 3-3

Loosen the Bolts to remove the Bonnet. See Fig. 3-4

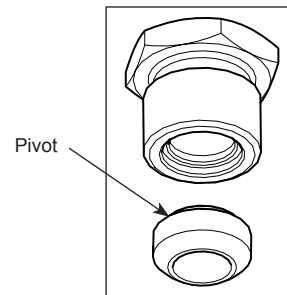

Fig. 3-2

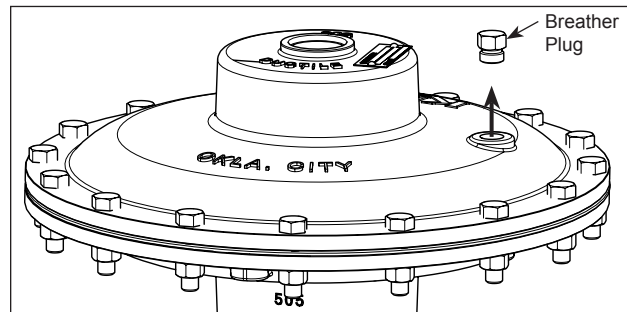

Fig. 3-3

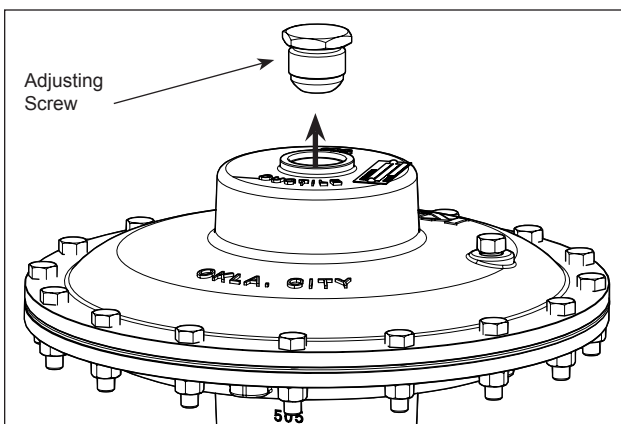

Fig. 3-1

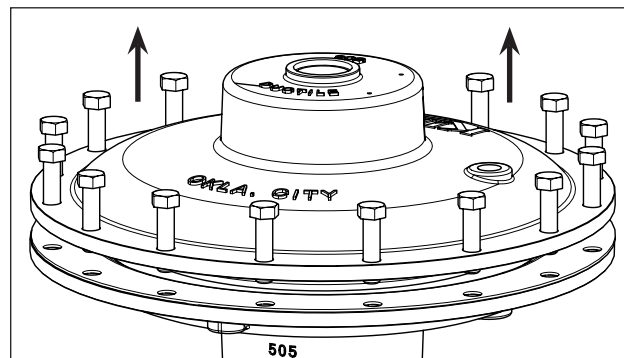

Fig. 3-4

DISASSEMBLY

4 Travel Indicator

Remove the Bolts from the Travel Indicator Block.

Remove the Block from the Stem.
See Fig. 4-1

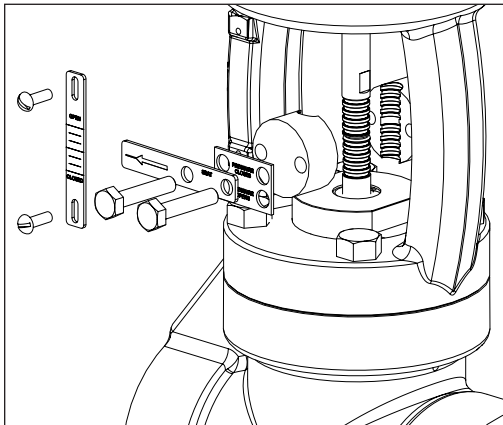

Fig. 4-1

5 Pivot, Spring Plate, Spring



NOTE:

Again sometimes the Pivot will separate from the Adjusting Screw and sit on top of the Spring Plate.

Remove Pivot from top of Spring Plate.

Remove Spring Plate.

Remove the spring from the Pivot sleeve. See Fig. 5-1

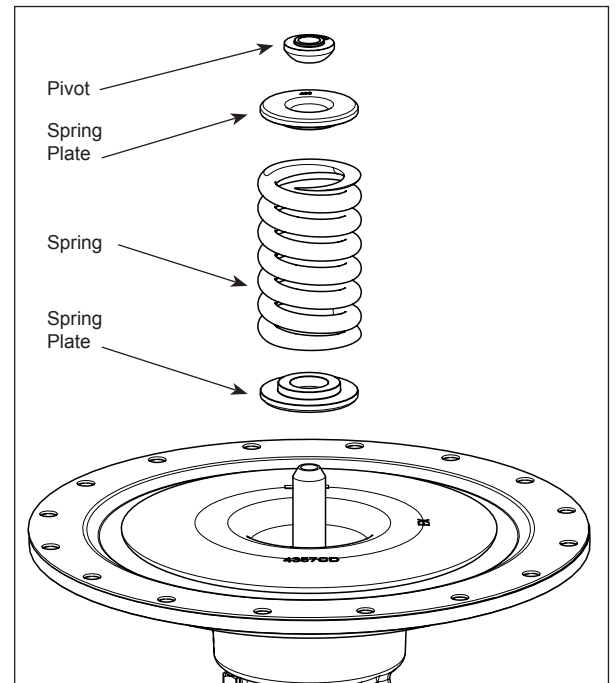

Fig. 5-1

Model: PO, PC

Installation, Operation & Maintenance Guide

DISASSEMBLY

6 Pivot Sleeve, Diaphragm Plate, Diaphragm Nut

Use a small adjustable wrench to hold the Upper Stem in place by the flats and spin the Diaphragm Plate in a counter clock wise direction loosening it from the Upper Stem. See Fig. 6-1



NOTE:

Peel the Diaphragm edge away from the Yoke, rotate the Diaphragm Assembly off the Upper Stem inside the Yoke See Fig. 6-1

Flip the Diaphragm Assembly over and remove the Diaphragm Nut by using a hammer and punch.
See Fig. 6-2

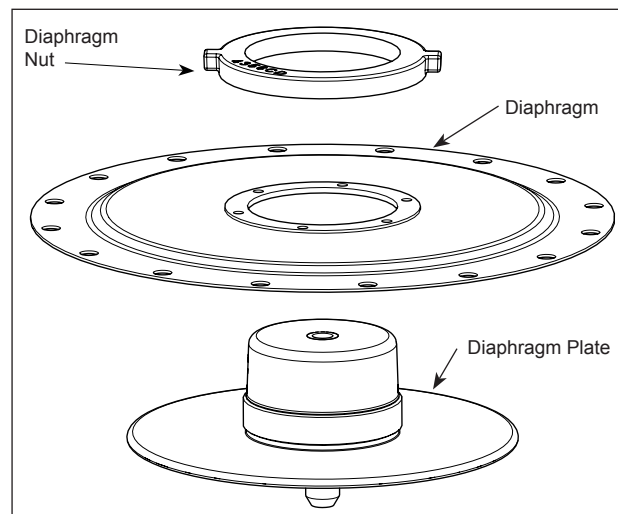

Fig. 6-2

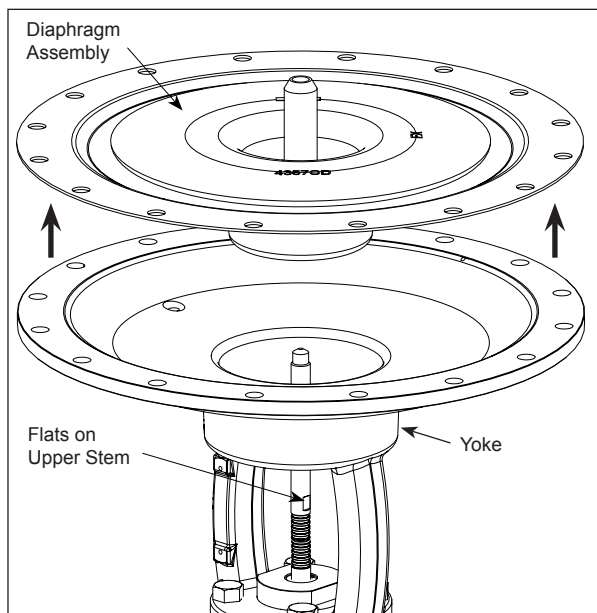

Fig. 6-1

DISASSEMBLY

7 Yoke Assembly

Use a wrench to remove the Bolts from the Yoke base.

Slide Yoke up from the Upper Housing. See Fig. 7-1

Flip the Yoke upside down, then use a socket wrench to remove the Lower Adjusting Screw. See Fig. 7-2

Slide out the Upper Stem from the Lower Adjusting Screw. See Fig. 7-3

Remove O-Ring from the inside of the Lower Adjusting Screw.

Use a pair of Snap Ring pliers to remove the Snap Ring. See Fig. 7-3

Remove the Retainer Washer.

Remove the Wiper from the Lower Adjusting Screw. See Fig. 7-3

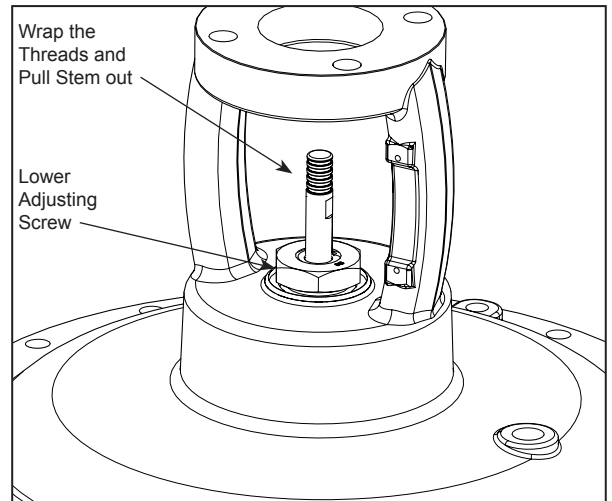

Fig. 7-2

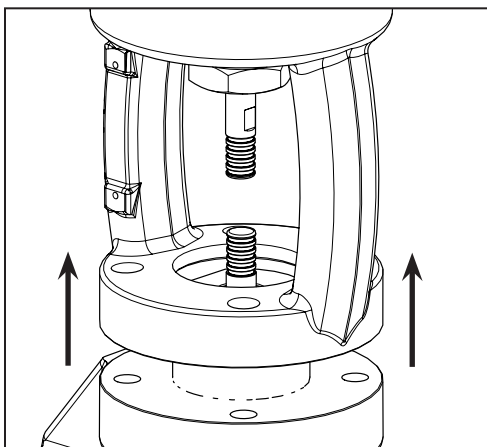

Fig. 7-1

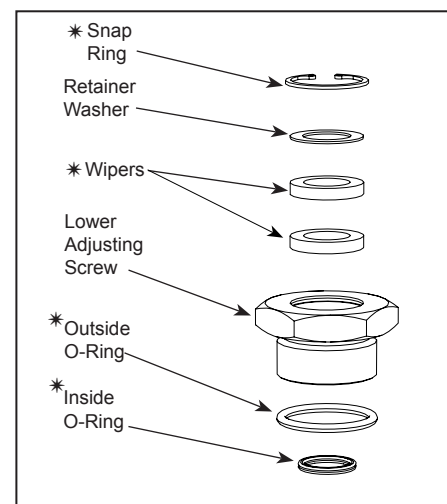

Fig. 7-3

* Recommended spare parts and stocked as repair kits

Model: PO, PC

Installation, Operation & Maintenance Guide

DISASSEMBLY

8 Packing Box

Wrench up on the flats machined into the Packing Box Body and remove by turning counter-clockwise.

Remove Packing Box from the Upper Housing. See Fig. 8-1

CAUTION:

When removing Packing Box from Body, if pressure starts to exit out of the safety relief hole than stop and check on isolation.

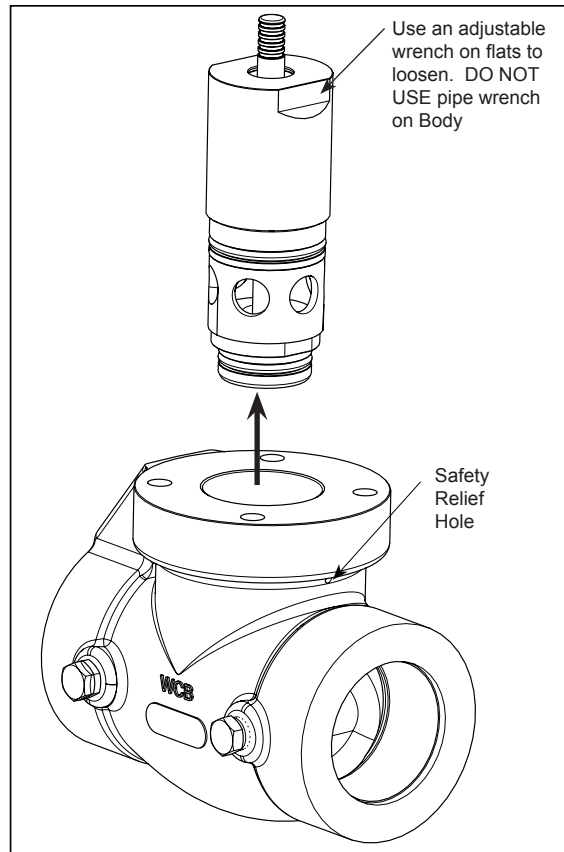

Fig. 8-1

Alternate Seat Removal

NOTE:

Occasionally the Cage unscrews from the Packing Box leaving the Cage, Seat and Lower Stem in the Body or the Seat will unscrew from Cage and remain in the Body.

See Fig. 8-2 & Fig. 8-3

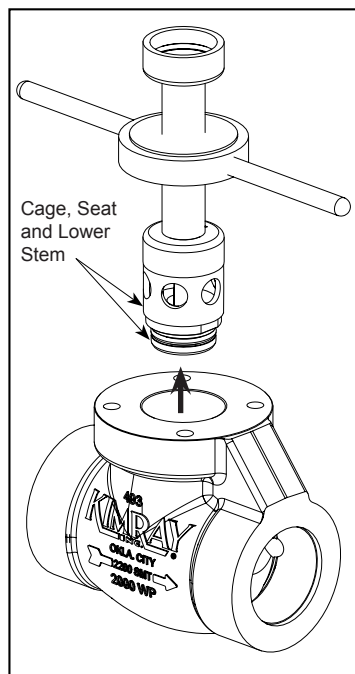

Fig. 8-2

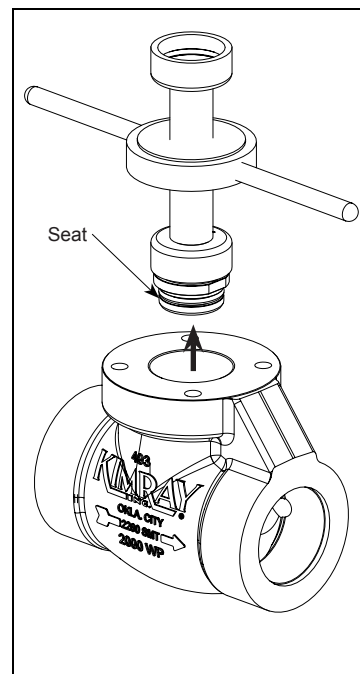

Fig. 8-3

DISASSEMBLY

9 Removing Packing Box

Flip the Packing Box up side down and clamp the two flat sides of the Packing Box in vise and loosen Seat with an adjustable wrench.

Leave the Seat attached to Cage. Insert a screw driver or small bar through the Cage and unscrew. See Fig. 9-1

**NOTE:**

Leaving the Seat attached will prevent the Cage from damaging the Cage wall or egg shaping.

Pull Stem and Cage out of Packing Box.

If Stem and Cage doesn't come out then flip the Packing Box over and tap the Stem with a hammer and a small punch. Remove Cage from the Ball Stem and Spring from the Packing Box.

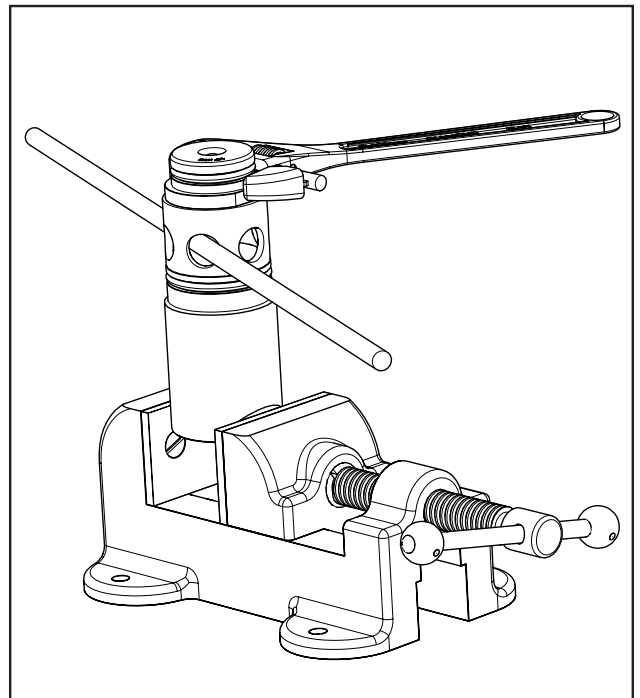

Fig. 9-1

Model: PO, PC

Installation, Operation & Maintenance Guide

DISASSEMBLY

10 Packing Box Assembly

Disassembly

Remove Snap Ring (Item 1).

Remove Retainer (Item 2).

Remove Wiper (Item 3).

Remove O-Ring.

Remove Packing Box and Packing Ring (Item 6).

Remove Packing Follower (Item 7).

Remove Spring (Item 8).

Remove Cage (item 9).

NOTE:

Using a punch, tap the Packing Rings and Sleeve through the bottom of the Packing Box.

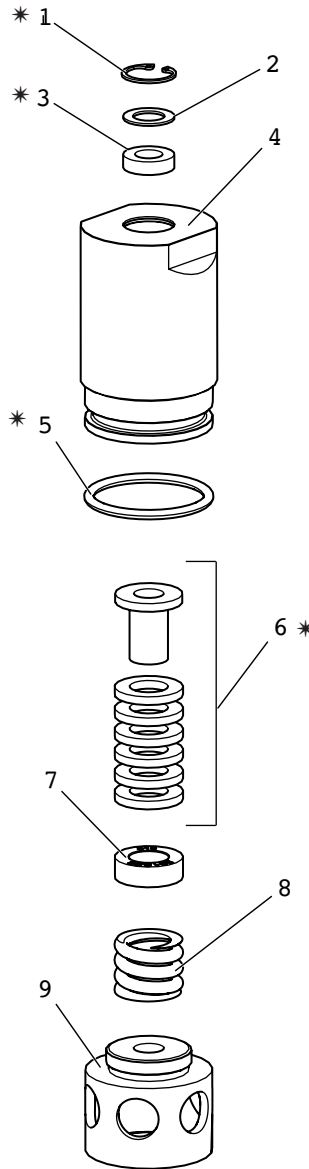

Fig. 10-1

Assembly

Check all parts for damages.

NOTE:

Apply all purpose grease the inside of the Packing Box before inserting parts.

Insert new Felt Wiper (Item 3).

Insert new Felt Retainer (Item 2).

Insert new Snap Ring (Item 1).

Use all purpose grease on the outside of the Packing Rings before inserting into the Packing Box (Item 6).

Use a socket to push the Packing down.

Insert Packing Follower (Item 7).

Re-use Spring (Item 8).

Use a brush or a grease gun to fill the Packing Box with all purpose grease.

TIP:

Use Kimray replacement parts only.

* Recommended spare parts and stocked as repair kits

Item	Part No. / Description	Qty
1	Snap Ring *	1
2	Retainer	1
3	Wiper *	1
4	Packing Box	1
5	O-Ring *	1
6	Packing Rings and Sleeve *	1

Item	Part No. / Description	Qty
7	Follower	1
8	Spring	1
9	Cage	1

INSPECTION

11 Inspection & Cleaning

Replace if the Packing Box shows excessive corrosion and wear.

Remove O-Ring from Packing Box.

Remove Follower from the Packing Box.

Check Point

Verify the Packing-Assembly and Follower are properly Seated in the Packing Box. Failure to do so could lead to Packing-Sleeve damage upon Stem installation. A socket is a handy and safe tool to perform this action.

Ball and Stem

Inspect the ball for pits and or grooves, and inspect the Stem for extensive scoring or scratches. Check for any bends on the Stem.
See Fig. 11-1

Seat

Check for scoring or scratches on the inside diameter. If the seal shows any indication of leakage.
See Fig. 11-2

Packing Box & Body

Replace the O-Ring.

Inspect the O.D. threads for nicks, burrs and flats.

Inspect the I.D. threads for nicks, burrs and flats.

A thread repair tool may be used for light damage, but Packing Box will need to be replaced for moderate to heavy damage.
See Fig. 11-3 & Fig. 11-4

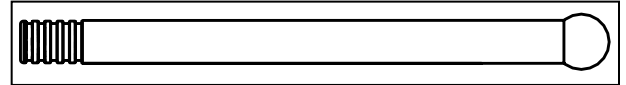

Fig. 11-1

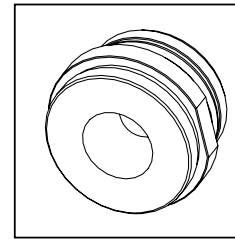

Fig. 11-2

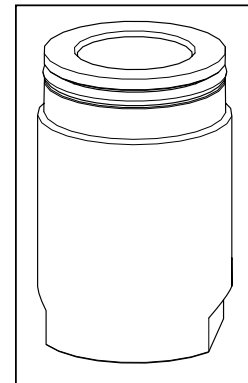

Fig. 11-3

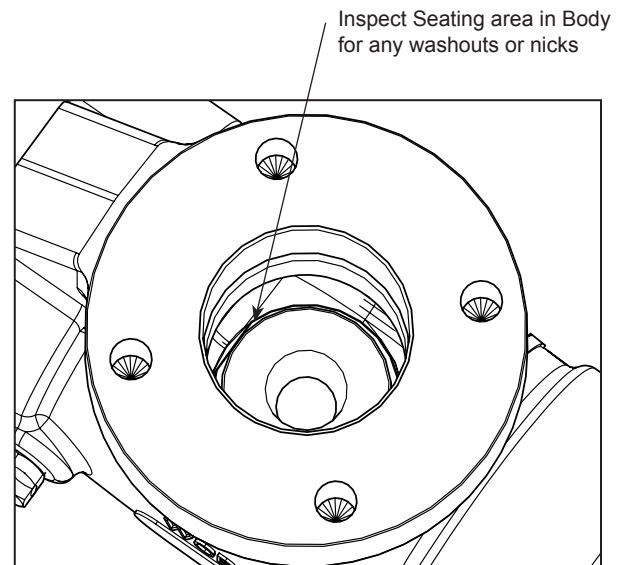

Fig. 11-4

Model: PO, PC

Installation, Operation & Maintenance Guide

ASSEMBLY

12 Cage, Packing

Apply all purpose grease on the outside of the Packing Box. DO NOT apply grease on the outer threads.



NOTE:

To prevent galling or seizing use a nickel impregnated PTFE thread sealant tape or equivalent.

Clean male and female threads thoroughly. Wrap the tape around the male thread, making three complete wraps. Keep the tape under tension as you are wrapping in the direction of the thread so the tape molds itself into the root of the thread. Make sure that the tape does not overlap the end of the fitting.



NOTE:

For poor quality or damaged threads that are hard to seal, such as parallel threads or threads on fittings subject to vibration, more than three wraps may be necessary.

Insert Packing Box into the Body.

Use an adjustable wrench on flats for tightening Packing Box. DO NOT use pipe wrench on Body. DO NOT OVER TIGHTEN.

Re-install the Cage on the Packing-box by applying downward pressure (slightly compressing the Spring) in order to start the threads. See Fig. 12-1

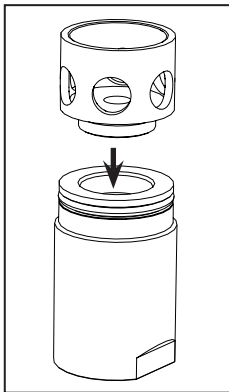

Fig. 12-1



NOTE:

Hand tighten the Cage at this point in assembly. The Cage will be fully tightened at Seat installation. See Fig. 12-2

Insert the Stem in Cage and thread the Seat in Cage. See Fig. 12-2 & Fig.12-3

Place the flat edges of Packing Box in vise and tighten.

Tap the Stem until the ball seats.

Use a brush to grease O-Rings.

Flip the Body upside down and tighten the Body on Packing Box Assembly. See Fig. 12-4

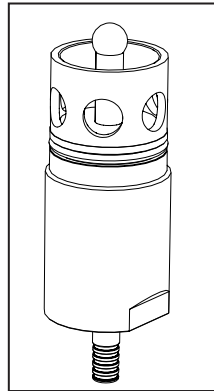

Fig. 12-2

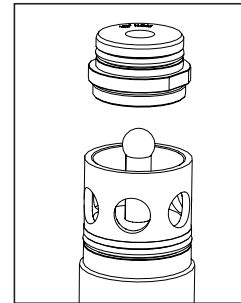

Fig. 12-3

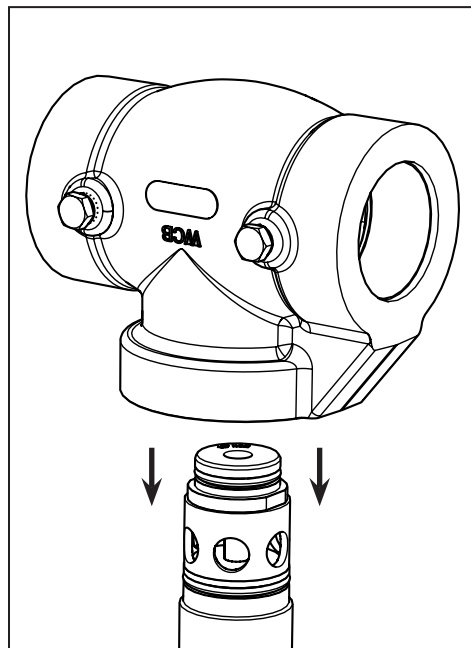

Fig. 12-4

ASSEMBLY

"V" Packing Box Assembly Option

1. Insert stem through lower end of cage, then through spring, and then through follower.
2. Slide male packing expander (D) over stem with flat end toward follower.
3. Apply grease to upper end of stem.
4. Carefully install one black "V" ring (C) over end of stem with open part of "V" going onto stem first. The ring will easily fit over grooved portion of stem. To fit ring onto main portion of stem, lean it to one side and turn ring while pressing it onto stem. See Fig. 12-5
5. Install the second black "V" ring (C) followed by the white "V" ring (D) in the same way you installed the first black ring.
6. Slide female packing expander (A) over stem with open "V" groove going onto stem first.
7. Apply grease to outside of packing rings, and push assembly into stuffing box.
8. Screw cage into stuffing box.
9. Screw seat into cage.

See Fig. 12-6

The stuffing box assembly can now be installed into the valve.

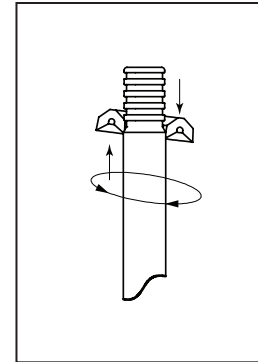

Fig. 12-5

! NOTE:

Never remove stem from packing without first removing the cage from the stuffing box. There must be no compression force on the packing from the spring while the stem is being removed or installed.

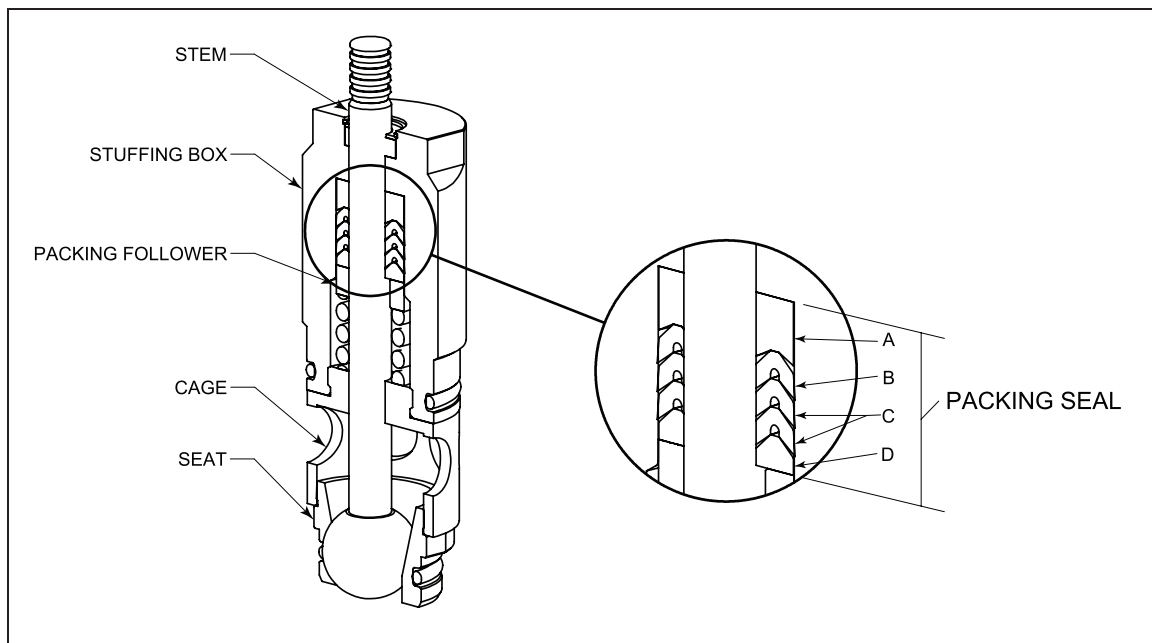

Fig. 12-6

Model: PO, PC

Installation, Operation & Maintenance Guide

ASSEMBLY

13 Diaphragm Assembly

Use a pair of brass jaws to hold the Diaphragm Plate in a vice.

Place Diaphragm on Diaphragm Plate. See Fig. 13-1

Thread Diaphragm Nut on Diaphragm Plate.



NOTE:

Make sure the Diaphragm does not wrinkle.

Insert Diaphragm Assembly in the center of the Yoke. See Fig. 13-2.

Place the Yoke on top of Body.

Insert Bolts and tighten with a wrench.

Use an adjustable wrench to hold the Upper Stem while tightening the Diaphragm Plate. See Fig. 13-3

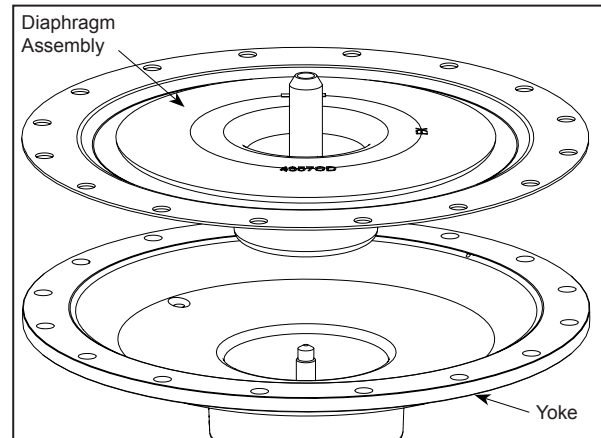

Fig. 13-2

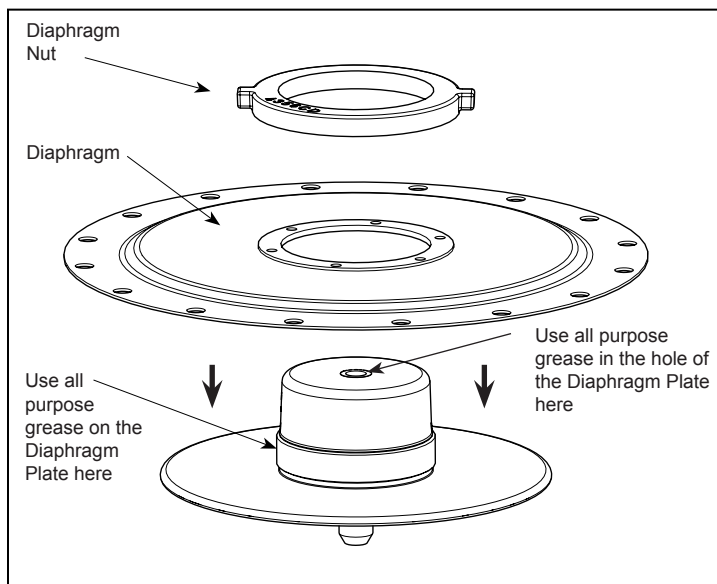

Fig. 13-1

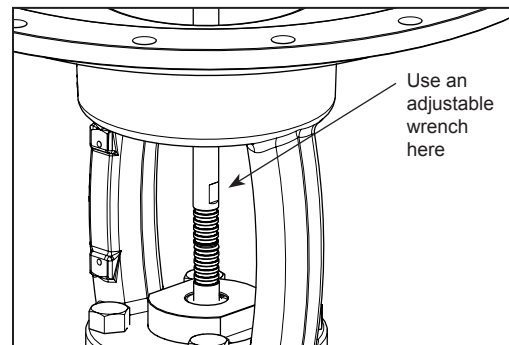

Fig. 13-3

ASSEMBLY

14 Internal Yoke Assembly

Use a brush to grease the Upper Pivot point.
See Fig. 14-1

Slide the Spring Plate on the Pivot Sleeve.
See Fig. 14-2

Insert the Spring on the Sleeve.

Insert the second Spring Plate on top of the Stem.

Place Bonnet on top of internal assembly and insert
screws. See Fig. 14-3

NOTE:

Make sure you tighten the Bolts in a criss-cross pattern to avoid any miss alignment. DO NOT OVER TIGHTEN. For 1in. and 2in. tighten Bolts from 25-30 ft/lbs torque. See Fig. 14-3

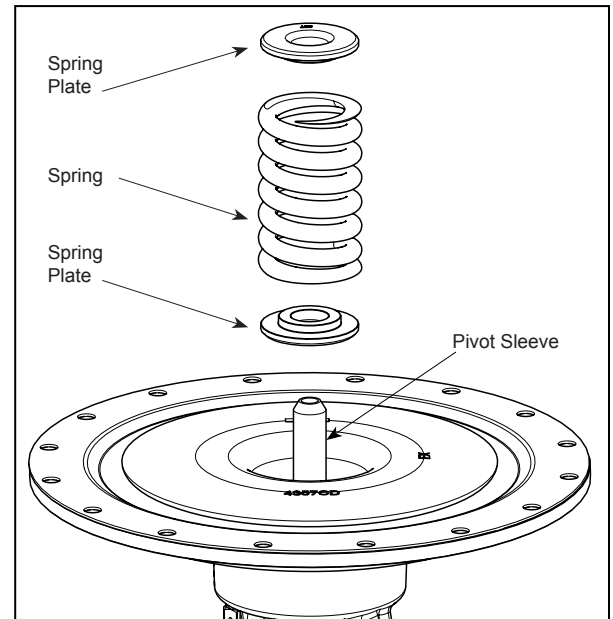

Fig. 14-2

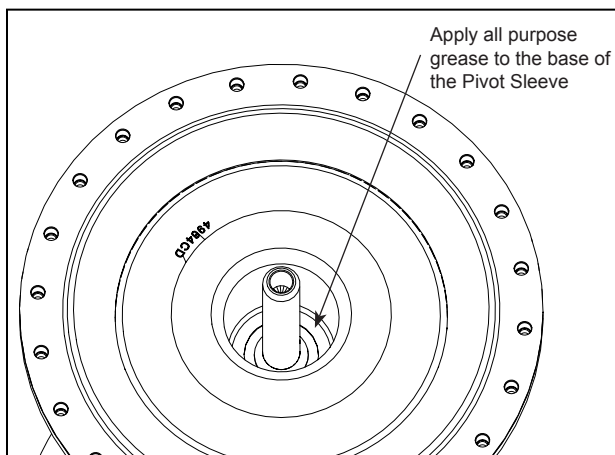

Fig. 14-1

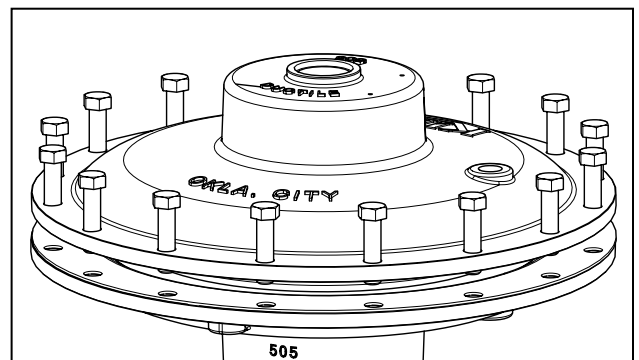

Fig. 14-3

Model: PO, PC

Installation, Operation & Maintenance Guide

ASSEMBLY

15 Pressure Closed



NOTE:

For pressure closed, flip Diaphragm Assembly upside down and place onto Yoke. See Fig. 15-1

Insert Bolts in Bonnet and tighten.

Insert Bolts in Bonnet and tighten. See Fig. 15-2

Insert O-Ring (not shown) on the Upper Adjusting Screw and tighten it on top of Bonnet. See Fig. 15-3

Insert Breather Plug. See Fig. 15-4



NOTE:

Make sure you tighten the Bolts in a criss-cross pattern to avoid any miss alignment. DO NOT OVER TIGHTEN. For 1in. and 2in. tighten Bolts from 25-30 ft/lbs torque. See Fig. 15-2

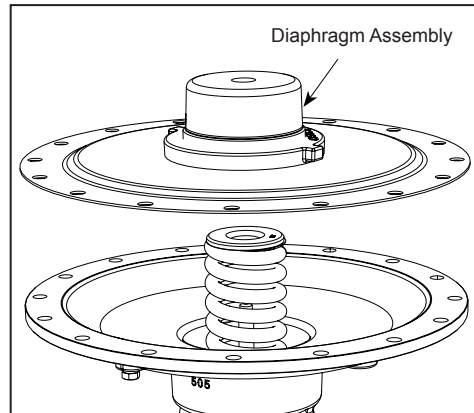

Fig. 15-1

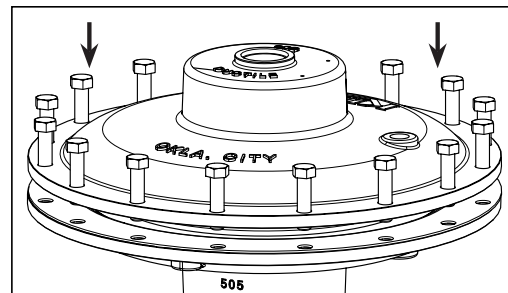

Fig. 15-2

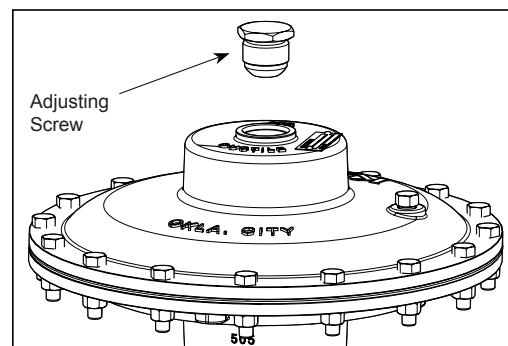

Fig. 15-3

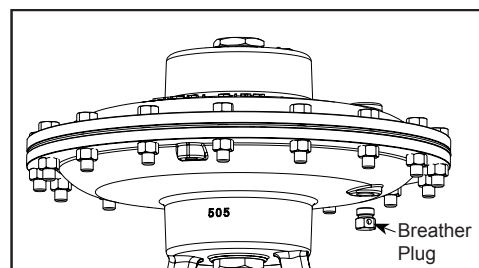

Fig. 15-4

ASSEMBLY

16 Travel Indicator

Get the Indicator Scale and line up the bottom "closed" line with the arrow on the Indicator. Use two drive screws to install it on the Yoke using a ball peen hammer.

 **NOTE:**

Make sure the Travel Indicator Tag shows the correct operation of the valve either PO or PC.

Insert Breather Plug.

When assembling the Coupling Block, make sure the bevels are in the same side of the Block.

Place the threaded half Block on back side.
See Fig. 16-1

Tighten the Bolts in the Coupling Block with a socket.

Make sure the Travel Indicator Tag shows the correct operation of the valve.

In this case we are converting from pressure opening to pressure close. See Fig. 16-2

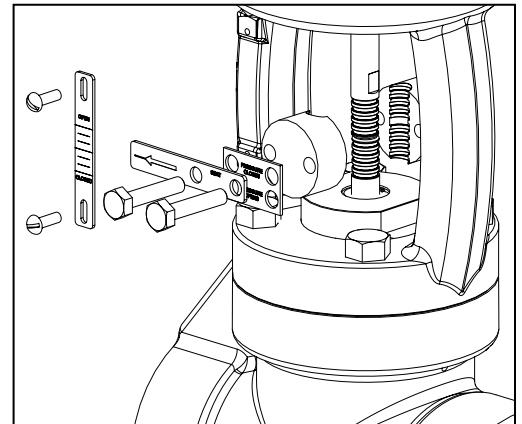

Fig. 16-1

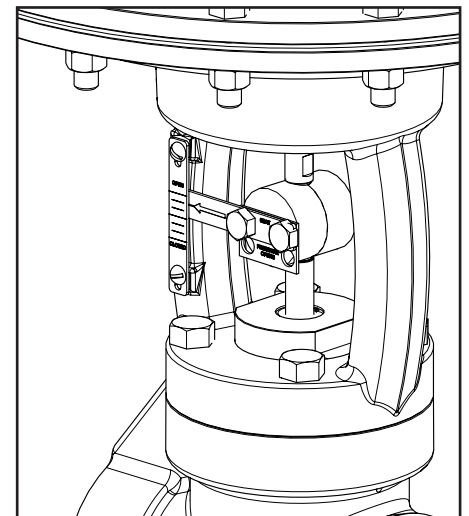

Fig. 16-2

Model: PO, PC

Installation, Operation & Maintenance Guide

TESTING

17 High Pressure Control Valve Testing

Use a male nipple and install in the pressure port on the Yoke. See Fig. 17-1. Test the valve following assembly test procedure.

Supply Pressure: **30 psi**.

Supply Connection: A device that will reduce your regulator end to any air supply connection.

NOTE:

When testing, it is important to have the test valve fixture screwed onto the valve for testing purposes.

Apply air supply pressure (**do not exceed 45 psi**) on Yoke. This will open the valve and will pressurize to bottom part of the Diaphragm.

Spray a soapy solution on the interface between the Bonnet, Yoke and lower Adjusting Screw to check for any leakage.

Check Travel Indicator. See Fig. 17-2

Install the Nameplate on top of the Bonnet with two drive screws and a ball peen hammer.

Replace the male nipple with a blue plug and thread it in the 1/4" NPT of the Yoke. See Fig. 17-3

Check Point

Apply air pressure on the upstream side of the valve and feel for any leakage downstream.

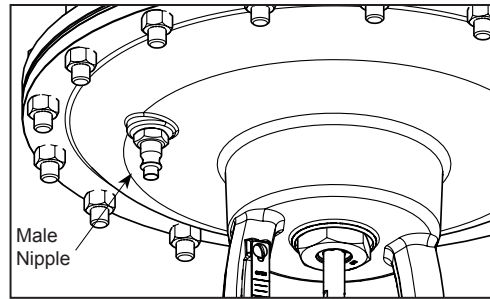

Fig. 17-1

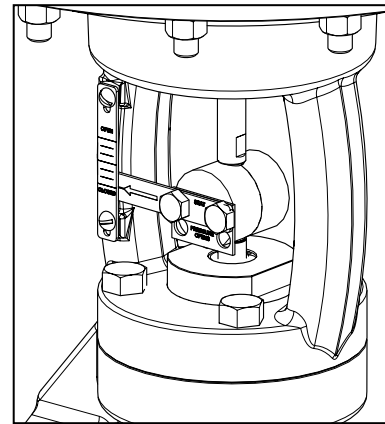

Fig. 17-2

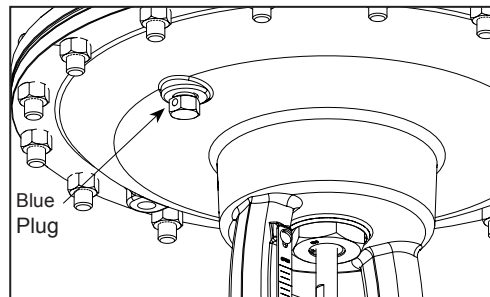

Fig. 17-3

Troubleshooting		
Problem	Possible Cause(s)	Possible Solution
Fluid leaking from Packing Box	Packing Box nut loose. Teflon Packing worn.	Tighten Packing until leaking stops. Replace Packing.
Valve leaks when closed	Tape or sealant stuck in valve. Soft Seat worn. Removable Seat worn.	Disassemble and clean Seat & Diaphragm. Replace Seat. Loosen Packing Nut to free shaft.
Erratic Operation	Packing Box nut too tight. Soft Seat leaking. Diaphragms hardened. Wet supply	Loosen Stuffing Box Nut. Inspect for deformations or obstructions in Seat. Replace Seat.

Kimray is an ISO 9001- certified manufacturer.
Kimray quality assurance process maintains strict controls
of materials and the certification of parts used in Kimray HPCV.

Please visit our website for up to date product data www.Kimray.com

WHO WE ARE

Kimray designs and manufactures oil and gas control products. Based on more than 65 years of pioneering product development, we provide products and services that are reliable, smart and inventive. We generate meaningful solutions by staying curious and engaging in customers' needs. Our product ideas are fueled by a deep desire to make a difference that is both personal and unique to the customer.

We have made it our life's work to provide products and services that are positively impactful. Through the years, this pursuit has built strong relationships. Our customers have known that buying from Kimray is about much more than the product. The relationships between Kimray representatives and our customers extend from before the sale through the life of the product. Those relationships, along with quality Kimray products, are the result of a company striving for excellence for our customers, our company and our community.

Visit Kimray.com to learn more about our company and the products we create.



Kimray.com

